

AN ORDINANCE

TO UPDATE THE GREENVILLE COUNTY SIGN ORDINANCE TO PROVIDE FOR THE ADMINISTRATION AND ENFORCEMENT OF THE REGULATION OF SIGNS AND SIGN STRUCTURES IN THE UNINCORPORATED AREA OF GREENVILLE COUNTY.

BE IT ORDAINED by the County Council of Greenville County, South Carolina:

Section 1. Sign Regulations. Greenville County Council hereby adopts the sign regulations attached hereto as *Exhibit A*, which shall serve as the Greenville County Sign Ordinance to provide for the administration and enforcement of the regulation of signs and sign structures in the unincorporated area of Greenville County. This Ordinance is adopted in accordance with the provisions of Section 4-9-30 and Title 6, Chapter 29, of the South Carolina Code of Laws, as amended.

Section 2. Repeal. All ordinances or parts of ordinances in conflict with this Ordinance or inconsistent with its provisions, including, but not limited to Chapter 19 of the Greenville County Code of Ordinances, titled "Signs", in its entirety, and Section 12:1.2 titled "Signage Standards" of the Greenville County Zoning Ordinance are hereby repealed or superseded to the extent necessary to give this Ordinance full force and effect.

Section 3. Severability. Should any section, paragraph, clause, phrase, or provision of this Ordinance be adjudged invalid or held unconstitutional by a court of competent jurisdiction, such declaration shall not affect the validity of this Ordinance as a whole or any part or provision thereof, other than the part so decided to be invalid or unconstitutional.

Section 4. Effective Date. This Ordinance shall take effect upon its adoption with the exception of "Article 6: Signs Not Requiring a Permit" which shall take effect six (6) months after the effective date herein.

DONE IN REGULAR MEETING THIS 15th DAY OF AUGUST, 2017.

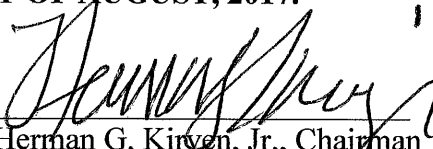
Herman G. Kirven, Jr., Chairman
Greenville County Council

ATTEST:

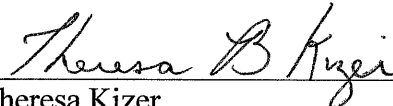
Theresa Kizer
Clerk to Council

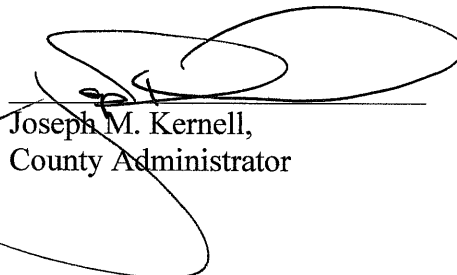
Joseph M. Kernell,
County Administrator

CHAPTER 19: SIGN REGULATIONS

Table of Contents

ARTICLE 1: AUTHORITY	1
1.1 Authority	1
1.2 Conflict with Other Laws and Regulations.....	1
1.3 Severability	2
ARTICLE 2: INTENT & PURPOSE.....	2
ARTICLE 3: DEFINITIONS.....	2
ARTICLE 4: ADMINISTRATION AND ENFORCEMENT.....	10
4.1. General	10
4.2. Permits.....	11
4.3. Off-premises Directional Sign Application Process	13
4.4. Landmark Signs.....	13
ARTICLE 5: GENERAL PROVISIONS	14
5.1. Placement	14
5.2. Unzoned Areas of the County	15
5.3. Maintenance, Repair, Removal	15
5.4. Nonconforming Signs.....	16
5.5. Abandoned Conforming Sign.....	16
5.6. Abandoned Non-Conforming Signs.....	17
5.7. Building Graphics.....	17
5.8. Noncommercial Copy.....	17
5.9. Sign Appearance and Materials.....	17
5.10. Addresses	17
5.11. Listed and Labeled.....	17
ARTICLE 6: SIGNS NOT REQUIRING A PERMIT	18
6.1. Exempt Signs.....	18
6.2. Other Signs Not Requiring A Permit	19
ARTICLE 7: PROHIBITED SIGNS	21
7.1. Signs imitating traffic or emergency signals	21
7.2. Public right-of-way.....	21
7.3. Signs on public property and public right-of-way.....	21

7.4. Obscene or Pornographic Signs.....	21
7.5. Signs employing motion.....	22
7.6. Temporary signs (Off-premises).....	22
7.7. Pennant & Streamer Signs.....	22
7.8. Balloons and Inflatable Signs.....	22
7.9. Bench signs.....	22
7.10. Mobile Signs.....	22
7.11. Windfeather Signs.....	22
7.12. Roof signs or any sign extending above the roof line.....	22
ARTICLE 8: SPECIFIC SIGN REQUIREMENTS.....	22
8.1. Sign Face and Sign Copy. (See Appendix B).....	22
8.2. Illumination.....	23
8.3. Message Centers.....	25
8.4. Requirements for specific sign types.....	26
8.5. Use Area Regulations.....	29
8.6. Off-premises Directional Sign Requirements.....	33
8.7. Temporary signs.....	35
8.8. Billboards.....	36
ARTICLE 9: GROUP COMMERCIAL DEVELOPMENTS, PLANNED COMMERCIAL CENTERS, AND BUSINESS PARKS.....	39
9.1. Group Commercial Developments, Planned Commercial Centers.....	39
9.2. Business Parks.....	41

ARTICLE 1: AUTHORITY

19:1 Authority

1.1 Authority

This chapter is adopted pursuant to the authority granted under S.C. Code Section 4-9-30 and S.C. Code, Title 6, Chapter 29, as amended.

1.2 Conflict with Other Laws and Regulations

Wherever the requirements made under authority of these regulations impose higher standards than are required in any other statute, local ordinance, or regulation, the provisions of these regulations shall govern. Wherever the provisions of any other statute, local ordinance, or regulations impose higher standards than are required by these regulations, the provisions of such statute, local ordinance, or regulations shall apply.

1.3 Severability

If for any reason one or more sections, sentences, clauses, or parts of this Ordinance are held unconstitutional or invalid, such decision shall not affect, impair, or invalidate the remaining provisions of this Ordinance.

ARTICLE 2: INTENT & PURPOSE

19:2 Purpose

The purpose of this ordinance is to provide fair and comprehensive regulations that will promote safety and orderly development of the community through the regulation of signs and sign structures. The intent of this ordinance is that the regulation of signs within the unincorporated areas of the county is necessary and in the public interest to encourage a positive visual environment and to afford equal and fair opportunity to advertise and promote products and services without discrimination and to protect the public health, safety and general welfare of the community.

ARTICLE 3: DEFINITIONS

19:3 Definitions

Except as specifically defined herein, all words in this chapter shall have their customary dictionary meanings. For the purpose of this ordinance, certain words or terms are defined as follows:

ABANDONED SIGN: A sign and its structure that has ceased to be used when the business activity or firm which such sign advertises is no longer in operation, or when the sign no longer displays copy.

ALTERATIONS AND REPAIRS: Improvements to a sign not exceeding 50% of the replacement value of the same type sign.

ANIMATION: The use of movement or some element thereof, to depict action or create a special effect or scene.

AWNING: An architectural projection or shelter, projecting from and supported by the exterior wall of a building and composed of a covering of rigid and non-rigid materials and/or fabric on a supporting framework that may be either permanent or retractable.

BUILDING FAÇADE: The portion of any exterior elevation of a building extending vertically from grade to the top of a parapet wall or eaves and horizontally across the entire width of the building elevation.

BUSINESS PARK: A development on a tract of land, either subdivided or on a single large lot, containing a number of separate office, commercial, or industrial buildings, supporting uses and open space that are designed, planned, constructed and managed on an integrated and coordinated basis.

CANOPY: A permanent structure attached or detached to a building for the purpose of providing shelter to patrons or automobiles or as a decorative feature on a building wall. A canopy is not a completely enclosed structure.

CLEARANCE: The vertical distance above the driveway, walkway or other surface, if specified, to the bottom edge of a sign. This term can also refer to a horizontal distance between two objects.

DIMENSIONAL REQUIREMENTS: Those measurements that identify the area and height requirements for signs.

FLASHING: A pattern of changing light illumination where the sign illumination alternates suddenly between fully illuminated and fully non-illuminated for the purpose of drawing attention to the sign.

FOOTCANDLE: A measure of illumination equal to one lumen per square foot and equal to .0929 LUX.

FRAME EFFECT: A visual effect on an electronic message center applied to a single frame to transition from one message to the next.

GROUP COMMERCIAL DEVELOPMENT: A development consisting of two (2) or more commercial, retail, office or industrial uses or buildings located on two (2) or more parcels, developed with a common plan for the protection, maintenance and improvement of the parcels and storm water facilities, and with access easements and rights in one or more of the parcels and governed by an owner's association or developed as a horizontal property regime.

HOME OCCUPATION: Any use of principal and accessory buildings clearly incidental to their uses for dwelling purposes and conducted for compensation by a resident thereof within a residential use area.

LABELED: An identification label applied on a product by the manufacturer that contains the name of the manufacturer, the function and performance characteristics of the product or material and the name and identification of an approved agency, and that indicates that the representative sample of the product or material has been tested and evaluated by an approved agency.

LISTED: Equipment, materials, products or services included in a list published by an organization acceptable to the Codes Administrator or his/her designee [recognized testing laboratory designed to assure compliance with applicable American National Standards (ANSI) and or the National Electric Code (NEC)] and concerned with evaluation of products or services that maintains periodic inspection of production of listed equipment or materials or periodic evaluation of services and whose listing states either that the equipment, material, product or service meets identified standards or has been tested and found suitable for a specified purpose.

LOGO: A business, institution, or use's trademark or symbol.

LINEAR FRONTAGE: The length of a property abutting a public right-of-way from one side lot line to another.

MANSARD ROOF: A four sided gambrel style hip roof characterized by two (2) slopes on each of its sides which forms a façade that may extend the building façade vertically above the eave line.

MURAL: A picture or image (including but not limited to painted art) which is painted constructed, or affixed on an exterior surface of a structure.

NONCONFORMING SIGN: A sign which was validly installed under laws or ordinances in effect at the time of its installation, but which is in conflict with the current provisions of this Code.

OFF-PREMISES SIGN: A sign that disseminates information and that directs persons to a different location from where the sign is located.

OFFICIAL NOTICE: Any notices issued by a court, public agency or officer.

ON-PREMISES SIGN: A sign that disseminates information that directly relates to the use of the property on which it is located.

PARAPET: An architectural façade feature which extends the building façade vertically above the eave line.

PLANNED COMMERCIAL CENTER: Two or more commercial, retail or office uses planned and developed as a unit on one parcel related in location and size and are reliant on common facilities such as vehicular access roads or drives and storm water facilities.

PUBLIC WAY: A street, alley, parking lot, public access drive or other parcel of land open to the outside air unobstructed from the ground to the sky and leading to a street which may have been deeded, dedicated or otherwise appropriated for public use.

RIGHT-OF-WAY: A legally established area or strip of land, either public or private, on which an irrevocable right of passage has been recorded, and which is occupied or intended to be

occupied by a street, utility service, water main, sanitary or storm sewer main, or other similar use.

ROOF LINE: The top edge of any façade, eave line, or in the case of an extended building façade, the uppermost point of said façade.

SETBACK: The minimum distance by which any sign must be separated from a street right-of-way, edge of road pavement, back of the curb, or lot line as prescribed herein.

SIGHT TRIANGLE: At the intersection of two public streets or a commercial driveway, a triangle formed by measuring from the point of intersection along the edge of pavement a minimum of twenty-five (25) feet in both directions, connecting the points so established to form a sight triangle on the area of the parcel adjacent to the street intersections.

Street or Driveway Intersection

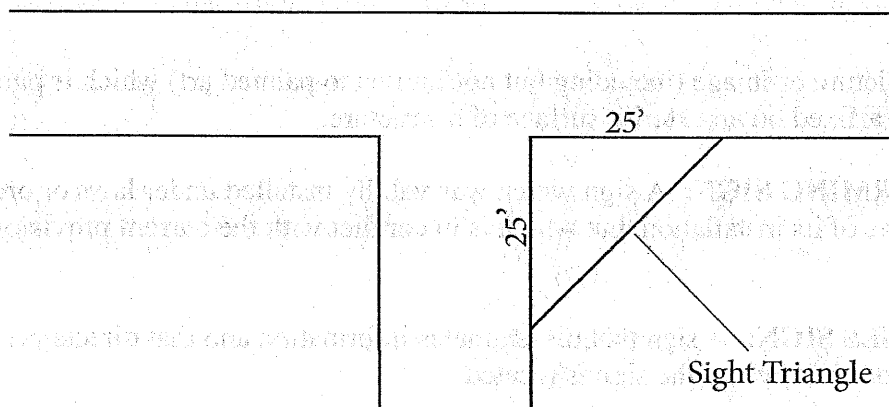

SIGN: Any device, structure, fixture, painting or visual image using words, graphics, symbols, numbers or letters designed for the purposes of communicating a message or attracting attention and supporting structure.

SIGN COPY AREA: The total dimensions of a sign surface used to display sign copy.

SIGN COPY: The words, logos, information, advertising, letters, numbers, figures, characters, artwork, symbols, insignia, or integral backgrounds that are used in a sign area excluding a street address.

SIGN FACE: The part of the sign that is or can be used for the sign copy area.

SIGN HEIGHT: A measurement from the highest point on a sign to the base where it touches the ground or surface upon which it is mounted or the road grade to which the sign is oriented, whichever is less.

USEABLE WALL AREA: The area of an exterior wall or surface area of a building or structure that excludes doors and includes building facades such as parapet walls.

VARIANCE: A variance is a waiver of the dimensional terms of this ordinance or other provisions specifically allowed upon review in this ordinance where such variance will not be contrary to the public interest and where, owing to conditions peculiar to the property and not the result of actions of the applicant, a literal enforcement of the ordinance would result in unnecessary and undue hardship; and does not involve a change in the use of the property.

SIGN TYPES

ANALOG MESSAGE CENTER: A sign with the capability to change content manually or automatically by remote input, direct manipulation, electronic means, or mechanical means. Such content is displayed without using a digital display. *See Appendix A: Figure 1.*

AWNING SIGN: Any sign displayed, applied or painted on an awning. *See Appendix A: Figure 2.*

BALLOON SIGN: A lighter-than-air gas filled device that is tethered to a fixed location or a device contrived to appear as such.

BANNER SIGN (FREESTANDING): A temporary sign of cloth, plastic, paper or similar non-rigid material attached to any staff, pole, rope, wire or framing which is anchored on two or more edges or at all four corners. *See Appendix A: Figure 3.*

BANNER SIGN (ATTACHED): A temporary sign of cloth, plastic, paper or similar non-rigid material attached to any structure which is anchored on two or more edges or at all four corners. *See Appendix A: Figure 3.*

BILLBOARD SIGN: A permanent, freestanding, off-premises sign. *See Appendix A: Figure 5.*

CANOPY SIGN: A sign displayed, applied or affixed to the visible surface(s) of an attached or free-standing canopy. *See Appendix A: Figure 6 & 7.*

DECORATIVE POST SIGN: A low profile freestanding sign mounted on two poles, posts, or columns placed at the outermost sides of the sign face or mounted on one pole, post or column with the sign suspended from an arm extension. Such signs shall include one or more architectural embellishments such as decorative caps, molding, decorative brackets, columns, base, top, or other feature. The sign face does not extend to the ground. Such a sign is on a premise and is oriented towards a public way. *See Appendix A: Figure 8 & 9.*

DIRECTIONAL SIGN (OFF-PREMISES): An off premise sign, specifically designed to provide directional or destination information.

DIRECTIONAL SIGN (ON-PREMISES): A sign with the purpose of guiding traffic, either vehicular or pedestrian into and/or throughout a site.

DIRECTORY SIGN: A sign on which the names and locations of occupants or the use of a building or property within a group commercial development or business park is identified. See *Appendix A: Figure 10*.

ELECTRONIC MESSAGE CENTER: An on-premises sign capable of displaying words, symbols, figures or images on a digital display and is electronically changed by remote or automatic means. See *Appendix A: Figure 1*.

EXEMPT SIGN: An on-premises sign intended for communicating or promoting goods and services provided on site, oriented to persons on the premise, and does not further promote the business' name by including the business' logo, insignias, trademarks etc.

FLAG: Any sign on cloth, plastic, or other similar non-rigid material attached to a pole or staff and having a wider than tall (horizontal) orientation whose rotation is determined by the wind direction. See *Appendix A: Figure 11*.

WINDFEATHER SIGN: A sign of cloth, plastic, or similar non-rigid material supported by a pole or staff and having a tall, narrow (vertical) orientation whose rotation is determined by the wind direction and is not permanently installed. See *Appendix A: Figure 12*.

FREESTANDING SIGN: A sign which is permanently affixed to the ground and which is not a part of a building or other structure.

HOURS OF OPERATION SIGN: A sign displayed near the entrance or on the entrance door to a premise and displays the days and times said premise is open.

INCIDENTAL SIGN: A sign that displays general site information, instructions, directives, or restrictions that are primarily oriented to pedestrians and motor vehicle operators who have entered a property from a public street.

INDOOR SIGN: Any sign which is erected and/or displayed inside of a structure and which does not qualify as a window sign.

INFLATABLE SIGN: A sign that is an air inflated object, made of flexible fabric and equipped with a portable blower motor that provides a flow of air into the device. See *Appendix A: Figure 13*.

ILLUMINATED SIGN: A sign characterized by the use of artificial light, either projecting through its surface(s) (internally illuminated); or reflecting off its surface(s) (externally illuminated).

MARQUEE SIGN: A sign on a permanent structure which projects over the entrance and is attached to and supported by a building. *See Appendix A: Figure 14.*

MEMORIAL SIGN/PLAQUE: Any sign displaying the name of buildings and/or other important elements on a site, such as the date of erection, and other elements involved, such as the architect or contractor.

MOBILE SIGN: A sign, including the trailer assembly or other transporting apparatus or any equipment to which the sign is attached, which may be moved from one location to another, is not permanently affixed to the ground, and is differentiated from a “moveable sign” in that it may be equipped for transportation by motor vehicle or other mechanical means. Trailer signs are considered to be mobile signs. *See Appendix A: Figure 15.*

MONUMENT SIGN: A freestanding sign whose face is the same width as or greater than the message portion of the sign from the top of the sign to the ground, and is permanently affixed to the ground. Such signs may include a contiguous structural base or planter box as part of the sign face. Such signs are not internally supported by poles or other structural devices. *See Appendix A: Figure 16.*

MOVEABLE SIGN: A sign which is movable by a person without aid of a motor vehicle or other mechanical equipment. *See Appendix A: Figure 17.*

MULTIPLE-FACED SIGN: A sign containing three or more faces. *See Appendix A: Figure 18.*

MULTIPLE-USE IDENTIFICATION SIGN: A sign stating the name of the development and its tenants.

OFFICIAL GOVERNMENT SIGN: Any sign placed by an official governmental entity such as but not limited to Greenville County or the South Carolina Department of Transportation.

PENNANT & STREAMER SIGN: A triangular or irregular piece of fabric or other material commonly attached in strings or strands intended to flap in the wind, secured to a fixed location. *See Appendix A: Figure 19-20.*

POLE SIGN: A sign that is supported by an uncovered freestanding pole. *See Appendix A: Figure 21.*

PREMISE IDENTIFICATION SIGN: A sign which identifies the premise on which it is located.

PROJECTING SIGN: Any sign, other than a “wall sign,” which is supported by a building and projects perpendicular to the applied surface. *See Appendix A: Figure 22.*

PYLON SIGN: A sign whose face covers an internal support system which may consist of internal poles or other structural devices and is permanently affixed to the ground and freestanding. *See Appendix A: Figure 23.*

ROOF SIGN: A sign wholly or partially supported by a structure that is erected, constructed, maintained, or projects above the roof line of that structure. *See Appendix A: Figure 24.*

TEMPORARY SIGN (ON-PREMISES): A non-permanent sign that advertises or references any goods, products, services, or facilities at the site such goods, products, services, or facilities are offered.

TEMPORARY SIGN (OFF PREMISES): A non-permanent sign that advertises or references any goods, products, services, or facilities, or that directs persons to a different location from where the sign is located.

TRAFFIC SIGN: Official highway route number signs, street name signs, wayfinding signs and other traffic signs erected and maintained on public highways and roads in the interest of public safety or for the regulation of traffic.

UNDER CANOPY/AWNING SIGN: Any sign suspended or hanging from a canopy or awning which is attached to the associated building for which the sign advertises and is perpendicular to the building front. *See Appendix A: Figure 25.*

V-SIGN: Signs containing two faces of approximately equal size, erected upon common or separate structures, positioned in a "V" shape with an interior angle between faces of not more than ninety (90) degrees (1.57 rad) with the distance between the sign faces not exceeding five (5) feet (1524 mm) at their closest point. *See Appendix A: Figure 26.*

WALL SIGN: Any sign painted on, attached flat, or attached parallel to the exterior wall or surface of a building or other structure and which may project from that wall or surface. *See Appendix A: Figure 27.*

WEEKEND DIRECTIONAL SIGN: An off-premises sign erected after 12 pm on Friday and removed not later than 7:00 am on the following Monday, the purpose of which is to direct to the indicated use.

WINDOW SIGN: A sign that is placed on or attached to a window or is placed within twelve inches of the interior of the window. *See Appendix A: Figure 28.*

YARD SIGN: A temporary sign whose sign face is supported by stakes or posts that is placed on a premise and is oriented towards a public way. *See Appendix A: Figure 29.*

ARTICLE 4: ADMINISTRATION AND ENFORCEMENT

19:4 Administration and Enforcement

4.1. General

4.1.1. *Those Designated To Administer And Enforce.* The County Council hereby designates the Codes Administrator or his/her designee to administer and enforce the provisions of this chapter.

4.1.2. *Notices and Orders*

- A. *Notice to person responsible.* Whenever the Codes Administrator or his/her designee determines that there has been a violation of this code or has grounds to believe that a violation has occurred, notice shall be given in the manner prescribed in Sections B and C to the person responsible for the violation as specified in this code.
- B. *Form.* Such notice prescribed in Section A shall be in accordance with all of the following:
 - 1. Be in writing.
 - 2. Include a description of the real estate sufficient for identification.
 - 3. Include a statement of the violation or violations and why the notice is being issued.
 - 4. Include a correction order allowing a reasonable time to make the repairs and improvements required to bring the signage into compliance with the provisions of this code.
 - 5. Inform the property owner or owner's authorized agent of the right to appeal.
 - 6. Include a statement of the right to file a lien collected on the tax bill.
- C. *Method of service.* Such notice shall be deemed to be properly served if a copy thereof is:
 - 1. Delivered personally;
 - 2. Sent by certified or first-class mail addressed to the last known address. If the notice is returned showing that the letter was not delivered, a copy thereof shall be posted in a conspicuous place in or about the structure affected by such notice."

4.1.3. *Noncompliance, Removal Of Sign*

- A. In the event any sign shall be installed, erected, and constructed in violation of any of the provisions of this article, the Codes Administrator or his/her designee shall by written notice inform the owner or lessee thereof of such violation and demand that it be corrected or that the offending sign be removed. If such order

is not complied with within seven (7) days after receipt of the notification, the Codes Administrator or his/her designee shall remove or cause such sign to be removed at the expense of the owner or lessee thereof.

- B. The Codes Administrator or his/her designee may remove and dispose of any sign or the sign's structure illegally placed in the public right-of-way without notice. Owners of signs and/or sign structures illegally placed in the public right-of-way shall be cited for the violation and fined in accordance with the provisions of subsection 4.2.6 *Penalties*.
- C. In the event a violation of this section has not been corrected within the time frame set forth in Section 3(a) above, the Codes Administrator or his/her designee has the authority to enter upon such lot or parcel of land and correct the violation, and the costs incurred as a result of such action (including inspection, administration, labor and (equipment costs) shall become a lien upon the property and shall be collected in the same manner as county taxes are collected.
- D. Any individual, firm or corporation who shall violate a provision of this chapter shall not be issued additional sign permits until such time as the violation has been corrected or the offending sign removed.

4.1.4. *Appeals, Variances, & Special Exceptions*

- A. *Appeals*. Any person who feels that the official charged with the administration and enforcement of this chapter has erred in their interpretation or application of any provision contained herein may appeal such decision to the Greenville County Board of Zoning Appeals. Such an appeal shall be filed in writing with the board within thirty (30) days after the receipt of an Official Notice of Violation by the Codes Administrator or his/her designee and shall specify the grounds for each appeal.
- B. *Variances*. Any person seeking relief from the regulations provided for herein may apply for a variance to the Greenville County Board of Zoning Appeals.
- C. *Special Exceptions*. Any person seeking a special exception provided for herein may apply for a special exception to the Greenville County Board of Zoning Appeals.
- D. *Application*. All appeals, variances and special exceptions shall be made in accordance with Section 3:3, Section 3:4, and Section 3:5 respectively in the Greenville County Zoning Ordinance.

4.2. Permits

- 4.2.1. *Permits Required*. Unless otherwise provided for in Article 6: Signs Not Requiring A Permit, no sign shall be erected, placed, constructed or structurally altered until such time as a sign permit has been obtained from the county.

- 4.2.2. *Application, Issuance, Conditions.* Applications for, the issuance of, and conditions pertaining to sign permits shall be established by the Codes Administrator.
- 4.2.3. *Required Submittal Documents.* All required documents shall be submitted in accordance with the requirements of the sign submittal policy as established by the Codes Administrator or his/her designee.
- 4.2.4. *Stop Work Order.* Whenever the Codes Administrator or his/her designee finds any work regulated by this code being performed either contrary to the provisions of this code or in a dangerous or unsafe manner, the Codes Administrator or his/her designee is authorized to issue a stop work order.
- 4.2.5. *Fees.* The fees shall be in accordance with the schedule established by the Greenville County Administrator.
- 4.2.6. *Penalties*
- A. Any person, firm, corporation or agent who violates a provision of this ordinance or fails to comply with any of the requirements thereof or who erects, constructs, alters or repairs a sign or sign structure in violation of the approved construction documents or directive of the Codes Administrator or his/her designee, or of a permit under the provisions of this ordinance, shall be subject to penalties as listed below.
 - B. Any person, firm, corporation or agent found to be in violation of the Sign Ordinance failing to comply with any of the requirements thereof may be cited and assessed, by civil penalty, an amount not more than two hundred dollars (\$200.00) for the first violation. Before being charged with a second violation, the person must be given seven calendar days to remedy the violation or submit an acceptable plan for correcting the violation.
 - C. A person who fails to correct a violation or fails to comply with any of the requirements thereof and has not submitted a plan for correcting a violation within seven (7) calendar days after citation or written notice may be cited and assessed, by civil penalty, an amount not to exceed two thousand dollars (\$2000.00) for each subsequent offense. Each day a violation continues is a separate offense.
 - D. An official authorized by Greenville County may deliver a civil citation to a person, firm, corporation, or agent who violates the provisions of this Code. The civil citation shall include the name and address of the violator; the nature of the violation; the location and time the violation occurred; the amount of the civil penalty assessed; and the defendant's right to stand trial before the Magistrate for the violation. A defendant may pay the penalty or elect to stand trial by giving the issuing agency written notice within ten (10) days of receipt of the

citation of his intention to stand trial. The issuing agency shall then forward the request to the Magistrate's Court to schedule a hearing on the request.

- E. If a defendant fails to file notice of his intention to stand trial for the violation as required by subsection (c), and fails to pay the penalty for the violation within thirty (30) days after receipt of the citation, the County agency may request adjudication of the case through Magistrate's Court. Upon receipt of a request for trial and summons from the County, the Magistrate shall promptly schedule the case for trial and summon the defendant to appear.
- F. In a proceeding for a civil violation a defendant may enter a plea of guilty, not guilty, or no contest. The court may render a verdict of "guilty" of the civil infraction or "not guilty" of the civil infraction.
- G. Upon adjudication of the case, the Magistrate may order the payment of the civil penalty. When a defendant has been found guilty of the violation and fails to pay the fine imposed by the court, the court may treat the failure as contempt of court.
- H. Adjudication of a civil citation is not a criminal conviction for any purpose, and does not impose any of the civil disabilities imposed by a criminal conviction.

4.3. Off-premises Directional Sign Application Process

All required documents shall be submitted in accordance with the requirements of the sign submittal policy as established by the Codes Administrator or his/her designee.

4.4. Landmark Signs

The purpose of these special sign regulations is to promote the protection of nonconforming signs that represent important aspects of the county's heritage, to enhance the character of the community by encouraging the restoration and retention of on-premises, nonconforming signs that are historically significant. Once designated as a Landmark Sign, the sign shall be considered to be a legal conforming sign.

All required documents shall be submitted in accordance with the requirements of the sign submittal policy as established by the Codes Administrator or his/her designee.

4.4.1. Designation Criteria.

- A. The Greenville County Historic Preservation Commission shall review and make a recommendation to the Codes Administrator or his/her designee. Codes Administrator or his/her designee may designate an existing on-premises sign as a Landmark Sign if it meets the following criteria:
 - 1. The sign has been in continuous existence at the present location for at least thirty (30) years.
 - 2. The sign is an on-premises sign, which meets at least five (5) of the following criteria:

- a. It was expressly designed for the business, institution, or other establishments at that location.
 - b. It bears a national or local emblem, logo, or other graphic that is unique to the property or the establishment.
 - c. The sign exhibits unique or rare characteristics that enhance the streetscape or identity of a neighborhood.
 - d. The sign is significant as evidence of the history of the product, business, or service advertised.
 - e. The sign is characteristic of a specific historic period.
 - f. The sign is integral to the building's design or physical fabric.
 - g. The sign represents an outstanding example of the sign maker's art due to craftsmanship, use of materials, or design.
3. The sign complies with the appropriate provisions of the South Carolina State Building and Electrical Codes (SC Code of Laws SECTION 6-9-130. Codes applicable to building inspections).
 4. If any portion of the sign is permitted to remain in or over a public right-of-way, a County or State approved encroachment agreement shall be executed.
 5. The sign is structurally safe or is capable of being made so without substantially altering its historical significance.
- B. Location. If a designated Landmark Sign is moved on-premises, it shall be subject to the location standards of this ordinance.
 - C. Should an applicant wish to appeal the Codes Administrator or his/her designee's decision an appeal may be made to the Board of Zoning Appeals.

ARTICLE 5: GENERAL PROVISIONS

19:5 General Provisions

5.1. Placement

5.1.1. Spacing.

- A. No sign within a Business Use Area shall be erected within a twenty-five (25) foot radius from any Residential Use Area boundary line.
- B. No freestanding sign shall be placed within a distance equal to its height to another permitted sign or structure.

- 5.1.2. *Grade level.* Sign height for signs that are located below or above the grade of the road to which they are oriented shall be measured from the grade of that street.

5.1.3. *Signs in Road Right-of-Way.* No sign other than an official traffic sign shall be placed within the road right-of-way unless specifically authorized herein or by the jurisdiction who owns the road right-of-way.

5.1.4. *Traffic Visibility*

- A. No sign should be placed in such a manner that it obstructs free and clear vision or be comprised of a shape or color which interferes with or confuses vision of any authorized traffic sign, signal or device.
- B. Signs located in a driveway sight triangle as defined in Section 19:3 shall not obstruct vision above a height of thirty (30) inches.
- C. No sign shall be located in an intersection sight triangle as defined in Section 19:3.
- D. *Setback.* Ten (10) feet
 - 1. *Calculating Minimum Setback.*
 - a. The minimum depth shall be measured from the property line, except that when a property line extends into the right-of-way area or a right-of-way has not been established or is not known, the setback shall be measured from the edge of the road pavement or back of the curb, if present.
 - 2. *Signs within Entrance Islands*
 - a. Signs within entrance islands may be allowed upon review by the Codes Administrator or his/her designee.
 - b. Signs in entrance islands shall be placed at least three (3) feet from the edge of curbs paralleling the travel lanes.
 - c. No sign shall be permitted in the last five (5) feet of the entrance island. Signs in an island shall be setback a minimum of ten (10) feet from the road right-of-way.

5.2. **Unzoned Areas of the County**

Signs in the unzoned areas of the county shall be subject to the requirements in Section 8.5 Use Area Regulations.

5.3. **Maintenance, Repair, Removal**

5.3.1. Any signs not meeting the following provisions shall be maintained, repaired, or removed within thirty (30) days after receipt of notification by the Codes Administrator or his/her designee:

- A. The area around the sign shall be properly maintained and clear of brush, trees and other obstacles around the sign that may obscure the sign face so as to make sign face readily visible.
- B. All inoperable lighting or damaged panels must be repaired or replaced.

C. All sign copy shall be maintained securely to the face and all missing copy must be replaced.

D. All signs shall be maintained in a structurally safe condition.

5.3.2. If the order is not complied with within the thirty (30) days receipt of the notification, the Codes Administrator or his/her designee shall be permitted to remove or cause such sign to be removed at the expense of the owner.

5.3.3. In the event a violation of this section has not been corrected within the time frame set forth in Section 5.3 above, the Codes Administrator or his/her designee has the authority to enter upon such lot or parcel of land and correct the violation, and the costs incurred as a result of such action (including inspection, administration, labor and (equipment costs) shall become a lien upon the property and shall be collected in the same manner as county taxes are collected.

5.4. Nonconforming Signs

5.4.1. Nonconforming signs may be continued in operation and maintained after the effective date of this chapter, provided that nonconforming signs shall not be:

- A. Changed to or replaced with another nonconforming sign;
- B. Structurally altered so as to extend their useful life;
- C. Expanded;
- D. Relocated;
- E. Re-established after damage or destruction of more than fifty (50) percent of the replacement value of the same type sign at the time of such damage or destruction; or,
- F. Modified in any way that would increase the degree of nonconformity of such sign. Except in the case of (E) hereinabove, this shall not prevent repairing or restoring to a safe condition any part of a sign or sign structure or normal maintenance operations performed on a sign or sign structure or replacement sign faces.
- G. Signs which are nonconforming or are made nonconforming subsequent to a right-of-way improvement shall be exempt from the setback provision of Section 5.1. All other provisions of Section 5.1 remain in effect.

5.5. Abandoned Conforming Sign

5.5.1. Any conforming sign associated with the business activity, firm, or associated use for which such sign advertises has ceased to be in operation for more than thirty (30) days must have their sign copy replaced with a blank or securely covered. No copy may be placed on the sign blank or cover except for panels advertising the associated use for sale, rent or lease. Turning a panel inside out shall not be considered a blank. All provisions pertaining to the maintenance of the sign shall apply.

5.5.2. If at any time the cover should become detached either partially or fully, the sign owner will be required to secure the cover immediately.

5.6. Abandoned Non-Conforming Signs

5.6.1. Non-conforming signs abandoned for a continuous period of more than one-hundred and eighty (180) days, shall be

- A. removed within thirty (30) days or;
- B. efforts shall be initiated to bring the sign into compliance with current standards within thirty (30) days after receipt of notification from the Codes Administrator or his/her designee (includes submittal of required permits and plans) and; required work shall be completed within sixty (60) days after receipt of notification from the Codes Administrator or his/her designee.

5.7. Building Graphics

Illustrations on buildings that contain no references to products or services otherwise known as murals, shall not be considered signs. Illustrations on buildings that do contain copy, symbols, or other references to products or services shall be considered wall signs and shall be subject to the regulations of the use area in which they are located.

5.8. Noncommercial Copy

5.8.1. Notwithstanding any other provisions of this chapter, any sign authorized by this chapter is allowed to contain noncommercial copy in lieu of any other copy.

5.9. Sign Appearance and Materials

Signs may utilize wood, metal, plastic or other materials for the structure and sign face and shall be constructed in a professional manner in accordance with the adopted building code in order to ensure safe installation. Additionally, the sign copy shall be professionally applied (screen printed, painted, or otherwise). Signs allowed without a permit in Section 6.1 may be exempt from this section.

5.10. Addresses

All freestanding signs shall provide the associated address number. The numbers must be a minimum of six (6) inches in height. Address numbers shall be displayed in contrast from the background to which the numbers are affixed or displayed.

5.11. Listed and Labeled

All signs utilizing electricity must be listed and labeled.

ARTICLE 6: SIGNS NOT REQUIRING A PERMIT

19:6 Signs not requiring a permit

The requirements of this article shall become effective six (6) months from the date of its passage.

A permit is not required for the following types of signs. Such signs shall not be considered when determining the allowable number or size of signs on any premise; provided, however, that they must comply with all other applicable sections of this chapter.

No sign in this section shall be placed on utility poles, retaining walls, landscape features (i.e. tree or rock), other sign structures or any fence.

6.1. Exempt Signs

6.1.1. General

- A. In no case should an exempt sign be positioned or designed in order to advertise or otherwise communicate with a person not on the property.
- B. Exempt signs shall be permitted in Business Use Areas as defined by Section 19:8.5
- C. No exempt sign shall be located within twenty-five (25) feet of the property line or street right-of-way whichever is greater.
- D. No copy on an exempt sign shall exceed six (6) inches in height.

6.1.2. *Moveable signs.*

- A. *Sign face.* The sign face shall not exceed six (6) square feet per face.
- B. *Height.* The sign height shall not exceed three (3) feet measured vertically from ground level to the top of the sign.

6.1.3. *Exempt Window Signs*

- A. Exempt window signs may be placed within twelve (12) inches of the window, on the interior of the window or the exterior of the window.
- B. Exempt window signs in combination with permitted window signs shall not exceed twenty (20) percent of the window area.

6.1.4. *Exempt Wall signs*

- A. Exempt wall signs may be located on the exterior wall of a structure.
- B. Exempt wall signs in combination with permitted wall signs shall not exceed twenty (20) percent of the useable wall area.
- C. Copy height on signs identifying an entrance shall not be limited to six (6) inches.

6.2. Other Signs Not Requiring A Permit

6.2.1. *Banner (freestanding) signs.* Such signs shall not require a permit if no more than one banner sign not exceeding fifty (50) square feet is located on a property. Such signs shall be erected no more than thirty (30) days in a three month period.

6.2.2. *Banner (attached) signs.* Such signs shall not require a permit if no more than one banner sign not exceeding fifty (50) square feet is located on a property.

6.2.3. *Memorial Sign/Plaque.* Such signs shall not exceed two (2) square feet.

6.2.4. *Flag.* Three (3) flags in addition to the total number of permitted signs.

6.2.5. *Murals which are not signs (according to Section 5.6)*

6.2.6. *Indoor signs*

6.2.7. *Official government signs*

6.2.8. *Official Notices*

6.2.9. *Incidental Signs*

A. *Premise Identification signs.* Such signs shall not exceed two (2) square foot in area.

B. *Directional signs (On-premises).* Such signs shall not exceed three (3) square feet and thirty (30) inches in height.

C. *Directory Signs.*

1. Directory Signs may be used within a group commercial development or business park

2. Sign copy on Directory Signs may not exceed six (6) inches in height.

D. *Hours of operation signs.* Such signs shall not exceed two (2) square feet. Such signs shall be located within three (3) feet from the entrance or on the entrance door.

6.2.10. *On-Premises Yard Sign*

A. No more than three (3) On-Premises yard signs may be displayed.

B. Should a site have two-hundred and fifty (250) feet of frontage or more, one additional on-premise yard sign may be allowed without a permit for every increment of two-hundred and fifty (250) feet of frontage above the initial two-hundred and fifty (250) feet of frontage.

C. Such signs shall not exceed six (6) square feet.

D. Such signs shall not exceed five (5) feet in height.

- E. Yard signs are permitted in any use area unless specifically restricted in a particular Special Use Area.

6.2.11. *On-Premises Decorative Post Sign*

- A. Two decorative post signs may be displayed on a premise while the premise is being marketed for sale, rent, or lease and/or while the premise is being developed.
- B. Such signs are permitted in Business Use Areas. Properties two (2) acres or larger in a Residential Use Area may erect decorative post signs in accordance with this section's requirements.
- C. Such signs shall be secured to the ground either by in-ground poles, posts, or columns or by an above ground stand structure.
- D. Such signs shall not exceed forty (40) square feet. All appurtenances or embellishments in addition to the sign area must be within the allowable square footage.
- E. Such signs shall not exceed ten (10) feet in height.
- F. Should the site have more than five-hundred (500) linear feet of road frontage, then two (2) decorative post signs shall be allowed when grouped together at intervals no less than two-hundred and fifty (250) feet.

6.2.12. *Weekend directional signs.* Weekend directional signs shall comply with the following requirements:

- A. Weekend directional signs may be placed off-premises from the advertised use;
- B. Written permission must be obtained from the property owner on which the sign is placed by the weekend directional sign owner for each sign placed off-premises from the advertised use;
- C. Sign area may not exceed twenty-four (24) inches by twenty-four (24) inches;
- D. Sign height shall not exceed three (3) feet above adjacent grade;
- E. Signs shall not encroach into the road right-of-way or sight triangle and shall not obstruct visibility at intersections;
- F. Signs shall not be placed before 12:00 p.m. on Friday evening and shall be completely removed in their entirety not later than 7:00 a.m. on the following Monday morning;

- G. Not more than two (2) signs per referenced use shall be allowed at an intersection;
- H. No weekend directional signs shall be placed outside a one hundred and sixty (160) foot radius of a street intersection as measured from the point of intersection.
- I. No sign permitted in this subsection shall be placed more than two (2) miles from the referenced use.
- J. No sign permitted in this subsection shall be placed on or abutting a road owned and maintained by the state of South Carolina unless specifically allowed by the South Carolina Department of Transportation.

ARTICLE 7: PROHIBITED SIGNS

19:7 Prohibited Signs

No sign explicitly prohibited herein may be permitted unless specifically allowed elsewhere in this ordinance.

7.1. Signs imitating traffic or emergency signals.

No sign shall be permitted which imitates an official traffic sign or signal, or contains words or symbols displayed in a manner which might mislead or confuse drivers of vehicles, or which displays intermittent lights resembling the color, size, shape, or order of lights customarily used in traffic signals or on emergency vehicles or law enforcement vehicles, except as part of a permitted private or public traffic control sign.

7.2. Public right-of-way.

No sign shall project into a public right-of-way except where specifically allowed in this code.

7.3. Signs on public property and public right-of-way.

Except as provided for elsewhere in this code, no off-premises sign shall be placed on or attached to any curb, sidewalk, utility pole, bridge, tree or other surface located on public property or placed in the public right-of-way.

7.4. Obscene or Pornographic Signs.

No sign, visible to the public, shall exhibit statements, words or pictures of an obscene or pornographic nature. For purposes of this subsection, obscene words, photographs, or depictions are defined as provided in S.C. Code, Section 16-15-305(B), (C), (D), and (E), as amended.

- 7.5. **Signs employing motion**
No sign may employ actual motion or the illusion of motion achieved through mechanical, environmental or electrical means. Flags are exempt from this prohibition.
- 7.6. **Temporary signs (Off-premises)**
- 7.7. **Pennant & Streamer Signs**
- 7.8. **Balloons and Inflatable Signs**
- 7.9. **Bench signs**
- 7.10. **Mobile Signs**
- 7.11. **Windfeather Signs**
- 7.12. **Roof signs or any sign extending above the roof line**

ARTICLE 8: SPECIFIC SIGN REQUIREMENTS

19:8 Specific Sign Requirements

- 8.1. **Sign Face and Sign Copy. (See Appendix B)**
Sign copy as defined in Article 3 herein may be applied to the sign face. The sign copy area on a permanent freestanding sign shall not exceed eighty (80) percent of the sign face. The sign copy area may not exceed the total allowable square footage in Section 19.8.5 or referenced therein.
 - 8.1.1. *Multiple sided signs.*
 - A. Only one (1) side of a double sided sign is counted in determining the area of sign faces. Where the two (2) sides are not of equal size, the larger of the two (2) sides is used for the determination of sign face size. All freestanding signs herein are considered to be double sided signs.
 - B. V-Signs are considered a double sided sign and V-Sign size standards are determined according to the double sided sign standard herein. Both sign sides must be attached at a point and the angle of the sides must not exceed ninety (90) degrees. V-sign sizes are determined according to the double sided sign standard above.

- C. Multiple-faced signs containing three (3) or more faces shall be expressed as the sum of the areas of all the faces. The total number of square feet for all sides shall not exceed the square footage sum of both sides on a double sided sign.

8.1.2. *Round, Oval & Irregularly shaped signs.* Such signs shall be measured based on the appropriate mathematical formula to obtain the sign area for a circle, an oval or irregularly shaped sign. The total number of square feet for all sides shall not exceed the square footage sum of both sides on a double sided sign.

8.1.3. *Calculating Sign Area & Sign Face Area*

- A. *Sign Face:* The sign face shall be calculated based on the part of the sign that is or can be utilized for the placement of sign copy (typically any surface perpendicular to the ground). *See Appendix B.*
- B. *Sign Copy Area:* The sign copy area shall be calculated based on the area of the smallest standard geometric shape capable of encompassing the perimeter of the sign copy.
- C. Sign Copy Area shall include integral background areas. In the case of signs in which multiple background areas are separated by open space, sign copy area shall be calculated based on the sum of the areas of all separate background areas but without regard for any open space between the separate background areas. Signs without integral background areas shall mean sign copy applied or affixed to any surface not specifically designed to serve as a sign background.
- D. *Exceptions*
 - 1. Decorative Post Sign structural supports not bearing information shall not be included in the computation of the sign copy area.
 - 2. The sign face on a decorative post sign may equal the size of the sign copy area.
 - 3. All decorative embellishments or appurtenances which are not a part of the sign face or sign copy area shall be allowed if such embellishments or appurtenances do not exceed twenty (20) percent of the permitted sign face area.

8.2. **illumination**

Signs may be internally or externally illuminated but shall not exceed a brightness level of 0.3 foot candles above ambient light as measured using a foot candle (Lux) meter at a preset distance depending on sign area, measured as in Table 19.8(a).

Table 19.8(a): Sign Illumination Measurement

Area of illuminated surface	Measurement
sq ft	Distance (ft)
10	32
15	39
20	45
25	50
30	55
35	59
40	63
45	67
50	71
55	74
60	77
65	81
70	84
75	87
80	89
85	92
90	95
95	97
100	100
105	103
110	105
115	107
120	110
125	112
130	114
135	116

* for signs with an area other than those specifically listed in the table (i.e., 12 sq ft.), the measurement distance will be whichever listed standard is closest. (i.e. 12 sq ft utilizes the 10 sq ft standard. 13 sq ft utilizes the 15 sq ft standard)

*Any sign larger than provided for in Table 19.8(a) shall measure distance by the following calculation: The square root of the product of the sign area and one-hundred.

$$\text{Measurement Distance} = \sqrt{(\text{square feet} * 100)}$$

Example using a 225 square foot sign

$$\text{Measurement Distance} = \sqrt{(225 * 100)} = 150 \text{ feet}$$

8.3. Message Centers

8.3.1. *Electronic Message Centers*

- A. Electronic Message Centers may not exceed seventy-five (75) percent of the total allowable sign copy area (not sign face) on any sign.
- B. Electronic Message centers shall be allowed subject to the following:
 - 1. In Business Use Areas (as defined by Section 19:8.5), Electronic Message Centers shall display static images for a period of at least three (3) seconds before transitioning to another static image. The use of frame effects is permitted. Flashing and animation are prohibited.
 - 2. Electronic Message Centers shall not be permitted in Residential Use Areas (as defined by Section 19:8.5) except for when installed on non-residential use signs in Residential Use Areas.
 - a. Any Electronic Message Center on a sign for a non-residential use in a Residential Use Area shall display static images for a period of at least five (5) seconds before instantaneously transitioning to another static image. Animation, flashing and frame effects are prohibited.
 - 3. All electronic message centers shall come equipped with automatic dimming technology which automatically adjusts the sign's brightness in direct correlation with ambient light conditions.
 - 4. No electronic message center shall exceed a brightness level of 0.3 foot candles above ambient light as measured using a foot candle (Lux) meter at a preset distance depending on sign area, measured as follows in Table 19.8(a).

8.3.2. *Analog Message Center.*

- A. Analog Message Centers shall be allowed subject to the following:
 - 1. Analog Message Centers may not exceed forty (40) percent of the total allowable sign copy area (not sign face) on any sign.
 - 2. Analog Message Centers must be internally illuminated and no analog message center shall exceed a brightness level of 0.3 foot candles above ambient light as measured using a foot candle (Lux) meter at a preset distance depending on sign area, measured as in Table 19.8(a).

3. Analog Message Centers may utilize manual or remote input either electronically or mechanically activated to change the sign content.

8.4. Requirements for specific sign types.

8.4.1. Wall Sign

- A. Wall sign copy area shall not exceed twenty (20) percent of the useable building wall area onto which such a sign is attached. Additionally, such signs shall not exceed two-hundred and twenty-five (225) square feet in size.
- B. The maximum allowable wall sign area per wall shall not be transferable to another wall.
- C. No wall sign shall extend above the parapet or roofline of the building to which the sign is attached. A wall sign shall not project more than twelve (12) inches from the building to which the sign is attached. Further, no wall sign or its supporting structure shall cover any window or part of a window.
- D. Wall signs are single sided signs.

8.4.2. Canopy and Awning signs

- A. The maximum allowable area for canopy signs, awning signs or a combination of such signs shall not exceed the maximum size permitted in Section 19.8.4 herein.
- B. Any sign permitted in this subsection shall be placed in accordance with the provisions of Section 19.5.1. unless otherwise provided for in this subsection.
- C. The minimum height from grade to the lowest edge of a sign shall be seven (7) feet.
- D. No sign may horizontally extend beyond the canopy or awning to which it is attached or affixed more than twelve inches unless otherwise allowed or restricted herein.

8.4.3. Detached Canopy Signs

- A. Where signs are mounted on detached canopies there may be no more than two (2) such signs on any canopy.
- B. Signs on detached canopies shall be mounted on the canopy face and shall not extend above the canopy roofline.
- C. Detached canopy signs shall not exceed twenty (20) percent of the detached canopy's face upon which the sign is placed.

- D. No column or supporting structure may be utilized in the calculation of square footage for the sign face.
- E. Any sign permitted in this subsection shall be placed in accordance with the provisions of Section 19.5.1. unless otherwise provided for in this subsection.
- F. Detached canopy signs shall not project more than twelve (12) inches from the canopy.

8.4.4. *Attached Canopy Signs*

- A. Attached canopies must be attached and extend from the face of a building.
- B. Attached canopy signs shall not exceed twenty (20) percent of the wall to which the canopy is attached and upon which the sign is placed (including the canopy face).
- C. No column or supporting structure may be utilized in the calculation of square footage for the sign face.

8.4.5. *Awning Signs*

- A. Awning signs shall not exceed twenty (20) percent of the wall to which the awning is attached and not more than forty (40) percent of the awning face.
- B. Awning signs may not project from the face of the awning

8.4.6. *Under canopy/awning signs*

- A. Hanging, suspended, or projecting signs are permitted under canopies or awnings and shall have a vertical clearance of no less than seven (7) feet in height and shall not project beyond the canopy or awning from which the sign is suspended.
- B. Hanging or suspended signs should be perpendicular to the building wall.
- C. Hanging or suspended signs over driveways, alleys, or parking areas are prohibited.
- D. Any sign permitted in this subsection shall be placed in accordance with the provisions of Section 19.5.1. unless otherwise provided for in this subsection.
- E. The minimum height from grade to the lowest edge of a projecting sign shall be seven (7) feet.
- F. Such signs shall not exceed four (4) square feet in size.

8.4.7. *Marquee signs*

- A. Marquee signs may project up to nine (9) feet into the required setback, but shall be no closer than two (2) feet to the back of curb or edge of pavement and shall meet the following additional requirements:
 - 1. The marquee sign structure shall not encroach into any required planting area.
 - 2. A marquee sign shall not extend vertically above the roofline or parapet wall of a building.
 - 3. The marquee sign structure shall not include useable building square footage for the portion that projects into the set back.
 - 4. If the marquee sign structure encroaches into the public right-of-way, then an encroachment permit is required from the South Carolina Department of Transportation (SCDOT) or Greenville County respectively. No encroachment permit will be issued for a sign which encroaches upon a road right-of-way.
- B. The minimum height from grade to the lowest edge of a marquee sign shall be nine (9) feet.
- C. Any sign permitted in this subsection shall be placed in accordance with the provisions of Section 19.5.1. unless otherwise provided for in this subsection.
- D. Marquee signs may contain changeable copy. The message shall not change more than once in a twenty-four (24) hour time period.
- E. Marquee signs may utilize Electronic Message Centers in accordance with the following provisions of Section 19.8.3.
- F. Marquee signs may be permitted by special exception upon review by the Board of Zoning Appeals in accordance with the provisions herein.

8.4.8. *Projecting signs*

- A. A projecting sign shall be allowed to project up to three (3) feet from the structure but shall be no closer than two (2) feet to the back of curb or edge of pavement and shall meet the following additional requirements:
 - 1. The maximum area of a projecting sign shall not exceed eighteen (18) square feet.
 - 2. If the projecting sign structure encroaches into the public right-of-way, then an encroachment permit is required from the South Carolina Department of Transportation (SCDOT) or Greenville County respectively. No encroachment permit will be issued for a sign which encroaches upon a road right-of-way.
 - 3. A projecting sign shall not extend vertically above the roofline or facade wall of a building.
 - 4. The minimum height from grade to the lowest edge of a projecting sign shall be seven (7) feet.
 - 5. Any sign permitted in this subsection shall be placed in accordance with the provisions of Section 19.5.1. unless otherwise provided for in this subsection.
 - 6. Projecting signs may be permitted by special exception upon review by the Board of Zoning Appeals in accordance with the provisions herein.

8.4.9. *Flags*

- A. Flags must be affixed to a freestanding flag pole in a manner that enables the flag to be raised and lowered or;
- B. Mounted by a bracket projecting at an angle from a building and can be removed by a person without aid of mechanical equipment.
- C. Any sign permitted in this subsection shall be placed in accordance with the provisions of Section 19.5.1. unless otherwise provided for in this subsection.

8.5. Use Area Regulations

Any sign permitted in this subsection shall be placed in accordance with the provisions of Section 19.5.1. unless otherwise provided for in this subsection.

8.5.1. *Residential Use Areas*

The Residential Use Area shall be defined as any property whose primary use is either single family residential or multi-family residential.

- A. *Single Family Residential.* Residential developments including but not limited to subdivisions, manufactured home parks, and Planned Residential Developments shall be regulated as follows:

Type:	Freestanding
Number:	1 two-sided sign per entrance or two separate sign faces may be used in conjunction with a wall, fence or other architectural entrance feature
Size:	20 square feet (sign copy area)
Height:	8' maximum

- B. *Multifamily Residential.* Multifamily or Multi-Dwelling residential development signs shall be regulated as follows:

Type:	Freestanding
Number:	1 two-sided sign per entrance or two separate sign faces may be used in conjunction with a wall, fence or other architectural entrance feature
Size:	50 square feet (sign face)
Height:	8' maximum

- C. Non-Residential uses in residentially zoned areas shall comply with the multi-family Residential Use Area Standards herein. In addition to the permitted freestanding sign, Non-Residential uses in residentially zoned areas may have one wall sign not to exceed twenty (20) percent of the useable wall area or 50 square feet (whichever is greater).
 - 1. Message Centers shall be allowed for non-residential uses in Residential use areas except for Home Occupations per the provisions of Section 19:8.3 Message Centers.
- D. *Home occupation signs.* One non-illuminated sign shall be permitted for each home occupation provided that the sign copy area of such signs does not exceed two (2) square feet in area and that such sign is mounted flat against the wall of the building in which such home occupation is conducted or flat against the wall of a principal structure.

8.5.2. *Business Use Areas*

The Business Use Area shall be defined as any property whose primary use is neither single family residential or multi-family residential and is not a Special Use Area.

- A. Except for sites with multiple street fronts, no business use area shall be permitted more than three (3) permitted signs total.
- B. Sites which have more than one street front may be allowed one (1) additional freestanding sign per additional street front in excess of the three (3) permitted sign standard. (i.e. a site with two street fronts will be permitted four (4) signs, two of which are freestanding signs oriented towards two different street fronts respectively.)
- C. Message Centers shall be allowed per the provisions of Section 19.8.3 Message Centers
- D. Signs in Business Use Areas shall be permitted in accordance with the standards in Table 19.8(b) and listed in this subsection.

Table 19.8(b): Business Use Area Sign Regulations

Sign Type	Number (Maximum combination of all signs regardless of type)	Size	Height
Freestanding	1 per street front	in accordance with Section 19.8.5	in accordance with Section 19.8.5.2(c)
Wall	Up to 3	20% of the useable wall area, 225 sq ft maximum	not above roof line
Window	Up to 3	20% window area, 225 sq ft maximum	not above roof line
Attached Canopy	Up to 3	20% of the useable wall area, 225 sq ft maximum	not above roof line
Detached Canopy	Up to 3	20% of canopy face, 225 sq ft maximum	not above roof line
Awning	Up to 3	20% of the useable wall area, 225 sq ft maximum	not above roof line
Under Canopy/Awning	Up to 3	4 sq ft	minimum 7' vertical clearance
Projecting	Up to 3	18 sq ft	not above roof line
Marquee	Up to 3	1sq ft per linear foot frontage, 225 sq ft maximum	not above roof line

E. Freestanding Sign Height and Size

1. Dimensional standard

- a. No freestanding sign in a Business Use Area shall exceed a height of twelve (12) feet and a sign face of eighty (80) square feet except where provided for herein. The sign copy area shall not exceed eighty (80) percent of the total allowable sign face.
2. All freestanding sign faces shall be either a monument or pylon style sign.
3. The Codes Administrator of his/her designee may allow an increase to the dimensional standard to allow for additional height, sign area square footage, and or allow the utilization of a pole sign design and construction in accordance with the measurements in Table 19.8(c) and the Special Provisions herein.

4. *Conditions:* Additional height and/or size may be allowed by incorporating two (2) or more of the following features
 - a. Use of back-lighted (halo) lettering, or carved, routed, or sandblasted signs with a three-dimensional textured surface integral to the design.
 - b. The application of brick, stone, stucco, or other approved masonry not less than two (2) feet in height from the base of the sign.
 - c. Shrubs spaced to provide a continuous screen around the base of the sign with a minimum of two (2) feet in height at the time of planting.
 - d. Reduction in the total number of signs allowed on a site.
 - e. Removal of all non-conforming signs on the site.

Table 19.8(c): Freestanding Sign Height and Size

mph	Sign Face Area (Max)	Height (Max)
35 or less	90	15
40	100	17
45	120	19
50	135	21
55	180	24
60	200	30
65+ or (interstate)	225	35

5. *Special Provisions:*
 - a. A pole sign may be allowed should the sign be located on a road whose speed limit is fifty-five (55) mph or higher and the appropriate conditions are met.
 - b. Freestanding signs on properties directly abutting an interstate highway or a frontage road shall be allowed variances in height, square footage, and sign type in accordance with the 65+ mph provisions of Table 19.8(c).
 - c. Signs may be allowed which are smaller than the dimensional standard.
 - i. Signs which are smaller than the dimensional standard may be allowed to be developed as a decorative post sign and shall include one or more of the conditions listed herein. (If used: the masonry provision must fully encase the posts of the sign)
 - d. No sign on a designated scenic highway shall exceed the dimensional standards of a sign permitted along a road with a thirty-five mile per hour

(35 mph) speed limit. Scenic highways are listed below and indicated on the map in Appendix C.

- i. *Location:* Designated Scenic highways shall include:
 1. U.S. Highway 25 north of Travelers Rest.
 2. U.S. Highway 276 west of the Town of Cleveland.
 3. S.C. Highways 11, 290, 414, 418, or 101.
 4. S.C. Highway 253 from Altamont Road to Highway 414.
 5. S.C. Highway 14 north of Greer city limits.
 6. Old U.S. Highway 25.
 7. Reedy Fork Road and Fork Shoals Road south of Donaldson Center.

8.5.3. Special Use Areas (Review Districts)

- A. Signs in any NC, (Neighborhood Commercial) and POD, (Planned Office Development) PD, (Planned Development) and FRD (Flexible Review District) shall comply with the limits of the district's statement of intent as approved by Greenville County and the requirements herein.
- B. No more than three signs shall be permitted per use in a Special Use Area unless the use is part of a Group Development, Planned Commercial Center and/or Business Park.
- C. The number of signs allowed in a Group Development, Planned Commercial Center and/or Business Park shall be determined in accordance with Article 9 herein.
- D. Freestanding signs:
 1. No freestanding sign shall exceed eight (8) feet in height.
 2. No freestanding sign shall be exceed forty (40) square feet in size.
 3. All freestanding signs shall be either a monument or pylon style sign.
- E. Wall Signs:
 1. Wall signs shall not exceed fifteen (15) percent of the useable wall area and shall not exceed one-hundred and eighty (180) square feet.
- F. Group Freestanding sign:
 1. Such signs shall not exceed sixteen (16) feet in height.
 2. Such signs shall not exceed eighty (80) square feet.
- G. Other sign types: Other specific sign types not addressed in this subsection shall meet all standards as set in 8.4 Requirements for specific sign types.

8.6. Off-premises Directional Sign Requirements

For the purposes of directing traffic to uses not located along primary streets, and to ensure that visual clutter is minimized, off-premises directional signs may be permitted subject to the following:

8.6.1. Requirements

A. All distances herein are measured as a radius from the referenced point.

B. *General and Dimensional Standards*

1. The permit holder shall allow a use to be identified on the sign subject to the following:
 - a. The use is under single ownership or management.
 - b. Such signs shall be a Decorative Post Sign Type
 - c. The entrance to the advertised use is located within a two (2) mile radius from the directional sign.
 - d. Five (5) signs per use shall be permitted.
 - e. Individual sign face shall not exceed thirty-two (32) square feet in area.
 - f. Signs shall not exceed ten (10) feet in height.

C. *Spacing Requirements:*

1. Except where two post signs are allowed side by side at an intersection no sign shall be located closer than two-hundred and fifty (250) linear feet to any other permitted off-premises directional sign on the same side of the road.
2. There shall be no more than two signs per street approaching an intersection erected within one-hundred and sixty (160) feet of a street intersection as measured from the point of intersection per intersecting road. (e.g. six total signs for a three-way intersection, eight signs for a four-way intersection, etc.).
3. Each pair of off-premises directional signs shall be located on the same side of the street and oriented towards the approaching street to which said pair is associated.
4. No permitted off-premises directional sign shall be located closer than twenty (20) linear feet to any on-premises sign(s).
5. Traffic Circles shall be allowed the same number of signs as a corresponding intersection type as defined by the total number approaching streets into the Traffic Circle (i.e. a traffic circle with four approaching streets would be allowed the same number of signs as a traditional Four-Way intersection) Additionally, permitted off-premises directional signs must be located a one-hundred and sixty (160) foot of the interior edge of the traffic circle.

D. *Permitted Copy*

Permitted Copy shall be limited exclusively to the identification of a use or occupancy located elsewhere and which tells the location of or route to such use or occupancy.

- E. *Illumination*
Off-premises Directional Signs shall not be illuminated.
- F. *Maintenance*: All signs shall be maintained in accordance with Section 19.5.3 herein. The person to whom the permit is issued is solely and exclusively responsible for the maintenance of the directional sign.

8.7. Temporary signs

Temporary signs in this section require a sign permit.

8.7.1. General Temporary Sign Provisions.

Temporary signs shall be placed in accordance with Section 19.5.1. The height of temporary signs not within established site clearance or setback areas shall be governed by the dimensional requirements of the use area in which they are located. Temporary signs shall be non-illuminated.

8.7.2. Temporary subdivision signs.

One temporary sign announcing a land subdivision development may be erected per entrance on the premises of the land subdivision, provided that such signs do not exceed fifty (50) square feet in area, are set back at least ten (10) feet from any property line, are spaced at least five-hundred (500) feet apart, and are removed within one (1) year from the date the sign permit was issued or upon the erection of a permanent sign whichever is sooner. Extensions may be granted upon approval of the Codes Administrator or his/her designee. Temporary subdivision signs shall be a decorative post sign type.

8.7.3. Special Event Signs.

Certain temporary signs including banners, streamers, balloons, pennants, windfeather signs and similar devices, mobile signs and inflatables may be permitted for the purposes of temporarily advertising non-residential uses in residential use areas, business use areas, and special use areas in accordance with the provisions herein.

- A. Signs permitted as part of a Special Event shall be displayed for no more than thirty (30) days in a three (3) month period.
- B. No sign shall be illuminated or placed within ten (10) feet of a public right-of-way. No sign shall be placed in the sight triangle.
- C. No mobile sign shall exceed fifty (50) square feet in size.
- D. No inflatable sign shall exceed the use area's permanent freestanding sign height or the roofline of the business' building at its full inflation.
- E. No inflatable sign shall be placed closer than twenty (20') feet from the business's permanent sign.

F. *Special Event Sign Options:*

A Special Event Sign applicant may select from the options below.

1. Choose two (2) of the following:
 - a. One (1) Windfeather sign per fifty (50) feet of road frontage. Three (3) maximum per street front; lots under one-hundred (100) foot frontage may have two (2) windfeather signs per street front
 - b. Pennant & Streamer Signs
 - c. Balloons
2. Choose one (1) of the following:
 - a. 1 banner per fifty (50) feet of road frontage; the size for each banner shall be limited to one (1) square foot per linear foot of frontage not to exceed two-hundred (200) in total aggregate square footage between multiple banners. If a single banner is used in lieu of multiple banners the size shall not exceed one-hundred and fifty (150) square feet.
 - i. No paper banners shall be allowed
 - ii. No banner shall extend above the second floor level of a building or forty-five (45) feet above grade; whichever is less
 - iii. Banners may be either attached (wall banners) or freestanding
 - b. One (1) Mobile signs
 - c. One Inflatable sign
 - d. One Moveable Sign (within the twenty-five (25) foot exempt sign setback)

8.8. Billboards.

8.8.1. *Relocation of billboards permitted.* Notwithstanding any other provision of this chapter, any billboard which was lawfully erected prior to June 10, 1986, may be relocated to a new site, provided the relocation meets the provisions of this chapter.

8.8.2. *Criteria for relocation of billboards.* No billboard shall be relocated to a new site except in accordance with the general provisions of this chapter, and except as follows:

- A. *Location.* Billboards shall only be permitted in C-2, S-1 and I-1 districts.
- B. *Spacing.* On all streets and highways within the jurisdiction of this chapter, no billboards may be established:
- C. Within 1,000 feet of any other billboard located on the same side of the street;
- D. Within 500 feet from the vertical point of any other billboard located on the opposite side of the street;
- E. Within 500 feet of residentially zoned property on the same side of and fronting the street in question;
- F. Within 500 feet of residentially zoned property on the opposite side of and fronting the street in question;
- G. At intersecting streets, within 500 feet of any other billboard measured by the curb line or curb line extension. A billboard may be located at this point or at a

vertical point on the opposite side of the street, provided all other criteria are met;

- H. Within 1,000 feet of any historic site, place or district that is recorded on the national register, or any public park, measured by the curb line of the existing streets. A billboard may be located at this point or at a vertical point on the opposite side of the street, provided all other criteria are met;
- I. Within 1,000 feet from the center of any designated scenic highway when locating a billboard on a street which intersects with a scenic highway.

When determining whether a proposed billboard meets the spacing requirements set forth herein, distances shall be measured from the center of the billboard and shall take into account any billboard, residential property, historic district, public park or scenic highway, regardless of whether it is located in the incorporated or unincorporated area of the county.

8.8.3. *Maximum allowable display area.*

- A. Six hundred seventy-two square feet per sign face.
- B. Twenty percent of the 672 square feet allowable for extended copy of "pop-ups."

8.8.4. *Maximum allowable height.*

- A. Fifty feet for painted bulletins (14 feet by 48 feet).
- B. Forty-five feet for poster panels (12 feet by 25 feet).
- C. Thirty feet for poster panels (6 feet by 12 feet).

All measurements shall be taken from the road grade level to which the sign is oriented.

8.8.5. *Minimum setback from right-of-way.*

- A. Twenty feet for painted bulletins (14 feet by 48 feet).
- B. Fifteen feet for poster panels (12 feet by 25 feet).
- C. Ten feet for poster panels (6 feet by 12 feet).

8.8.6. *Abandoned signs.* A billboard without copy shall either display copy or be removed within 90 days after official notification from the zoning administrator.

8.8.7. *Scenic highway.* No billboards shall be allowed on the following scenic highways and corridors: South Carolina Highway No. 11 Corridor (county portion), designated as the Cherokee Foothills Scenic Highway; Interstate Highway I-185 "Southern Connector" and Haywood-Howell Road.

8.8.8. *Permit issuance.*

- A. *Permits for existing billboards.* All billboards existing in the county which were lawfully erected prior to June 10, 1986, shall be required to be re-permitted within 90 days after the effective date of this section. In order to obtain the permit, the owner shall furnish the county with the following information on

each billboard:

1. Location.
2. Color photographs of each face and support structure.
3. Size description of each face, excluding pop-ups. No initial fee shall be charged for re-permitting existing billboards.

B. *Permits for relocated billboards.* A permit for the relocation of a billboard shall not be issued by the county unless:

1. An officer of the company applying for a permit to relocate a sign certifies in writing that the company has provided the information required by subsection 8.8.8. (A) above for all of its existing billboards in the county.
2. The county has certified that the off-premise sign at the original location has been completely removed.
3. The county has verified that the proposed billboard and its proposed location meet the criteria set forth in this section.
4. All other requirements for obtaining a permit have been met, including the payment of a permit fee as charged by the county codes department.

No permit for the relocation of a billboard shall be issued if the company requesting such permit is presently in violation of any of the provisions of this chapter.

C. *Posting of permits.* The county codes department shall issue all permits required by this section in duplicate, one of which shall be weather resistant. The owner of each billboard in the county shall be responsible for affixing the weather resistant permit to the billboard in a prominent location and for ensuring that such permit is continuously attached at all times thereafter.

D. *Renewal of permits.* All billboard permits issued in accordance with this section shall be valid only for the calendar year in which they are issued and shall be renewed not later than January 15th of each calendar year. A renewal fee of \$75 shall be charged for each billboard permit renewed. Any billboard owner who fails to remit the \$75 renewal fee by January 15th shall be charged an additional \$25 late fee for each billboard permit renewed. In the event that any billboard owner fails to remit the renewal fee and the late fee by February 15, the county shall revoke the permit, and the billboard owner shall be required to remove the billboard within 30 days.

8.8.9. *Construction of relocated signs.*

- A. Any billboard relocated pursuant to the provisions of this chapter must be constructed within 12 months from the date the permit is issued.
- B. A relocated billboard shall have no more faces than it had at its previous location.
- C. The faces or faces of a relocated billboard shall have no more display area

(square footage) per face than it had at its previous location. In no event shall the face of a relocated billboard exceed the maximum allowable display area set forth in subsection 8.8.3. herein.

8.8.10. Billboard illumination

- A. Any billboards either internally or externally illuminated shall not exceed the limits of Section 8.2 and Table 19.8(a).

ARTICLE 9: GROUP COMMERCIAL DEVELOPMENTS, PLANNED COMMERCIAL CENTERS, AND BUSINESS PARKS

19:9 Group Commercial Developments, Planned Commercial Centers, and Business Parks

Except where specifically permitted in this article sign types shall be regulated in the same way as Section 8.4.2 Business Use area.

9.1. Group Commercial Developments, Planned Commercial Centers

9.1.1. Freestanding Signs

- A. Developments approved as a Group Commercial Development or Planned Commercial Centers shall be allowed one (1) freestanding sign per entrance. Each sign shall not exceed thirty-five feet in height and one (1) square foot of sign face for each linear foot of continuous street frontage or two-hundred and twenty-five (225) square feet, whichever is less. Freestanding Multiple-Use Identification signs shall include the name of the development.

9.1.2. Wall Signs

- A. When a Group Commercial Development or Planned Commercial Center has two thousand (2,000) linear feet of continuous frontage or more on a public road, the following provisions (including Table 9.1) shall supplement the established criteria with regard to wall signs.

1. Tenant Types

- a. Major Tenants are defined as those tenants having a lease area of more than twenty-five thousand (25,000) square feet and having a minimum of two (2) sides of its building exposed to a public way.
- b. Minor Tenants are defined as those tenants having a lease area of less than twenty-five thousand (25,000) square feet.

Table 9.1: Wall Signs in a Group Commercial Development or Planned Commercial Center

	Major Tenants (Main Building)	Minor Tenants	Ancillary Building to Major Tenant
Number of signs	1 per Building side visible from a public way	1 at the point nearest the associated use's entrance	2 at the point nearest the associated use's entrance
Height of sign copy	8'	6'	6'
Area	20% of useable wall area	20% of useable wall area	20% of useable wall area
Placement	At least 24" or more below roof line	At least 24" or more below roof line	At least 24" or more below roof line
Projection	3' from building or canopy	1' from building or canopy	1' from building or canopy
Building entrance sign (per entrance)	1 wall sign; 1 on door	N/A	1 wall sign; 1 on door
Rear Service entrance wall sign (10 sq ft)	1	1	1
Additional Sign for end units	N/A	1	1

2. Signs in Group Commercial Development or a Planned Commercial Center shall conform to any applicable current federal or state laws which may supersede those requirements herein.
3. Building entrance signs shall identify the name for the Group Commercial Development or Planned Commercial Center.
4. The bottom edge of any wall sign shall not be lower than seven (7) feet from the ground.

9.1.3. *Group Commercial Development or Planned Commercial Center Building Entrance Signs*

- A. When the Group Commercial Development or Planned Commercial Center has one or more dedicated public building entrances (not a tenant entrance) then the Group Commercial Development or Planned Commercial Center may have an entrance sign placed at each entrance.
- B. Such signs shall either be wall mounted, under-canopy signs, or a marquee.
- C. Such signs shall not exceed the collective width of the entrance as measured from the farthest edge of the entrance door on one side to the farthest edge of the entrance door on the other side. Gaps between multiple doors shall be included

in the width measurement.

D. Such signs shall not exceed one-hundred and twenty square feet in total area.

9.2. Business Parks

9.2.1. Business Park Sign

Type: Freestanding (in accordance with Section 19.8.5)

Number: 1 per street front or entrance

Size: In accordance with Section 19.8.5

Height: In accordance with Section 19.8.5

- A. Business parks may have a development sign stating only the name of the Business Park.
- B. Such signs shall be allowed at each entrance to the Business Park (no further than one-hundred (100) feet from street to which the entrance connects as measured from the road centerline).

9.2.2. Directory signs in Business Parks

- A. Directory signs may be allowed when located at intersections or in a designed pull-off out of the flow of traffic along the entrance street. Directory signs must be set further back than the Business Park Sign (Greater than one-hundred (100) feet from the street to which the entrance connects as measured from the road centerline).

9.2.3. Tenant signs in Business Parks

- A. Tenant signs may be allowed freestanding and wall signs in a Business Park in addition to the Business Park development sign in accordance with the requirements herein:

Type: Freestanding (in accordance with Section 19.8.1) & Wall

Number: 1 per street front or entrance
Wall signs 20% useable wall area, 200 sq ft max.

Size: 30 sq ft total,

Height: 8'

Appendix A

Sign Types

Figure 1. Message Center

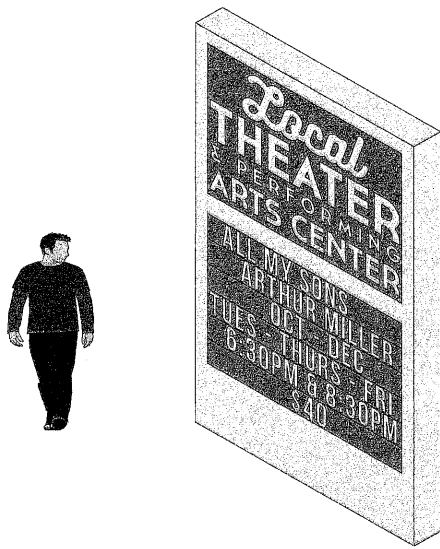

Figure 2. Awning Sign

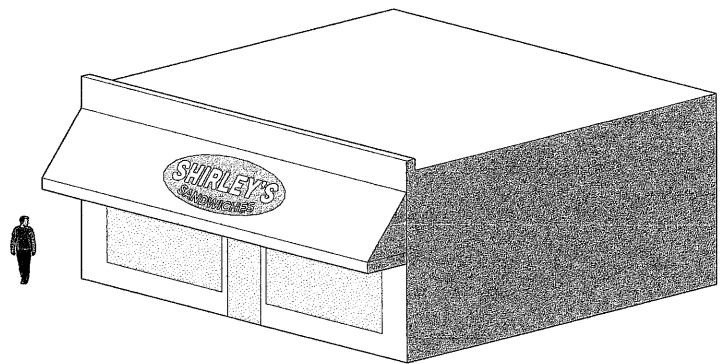

Figure 3. Banner Sign (freestanding & attached)

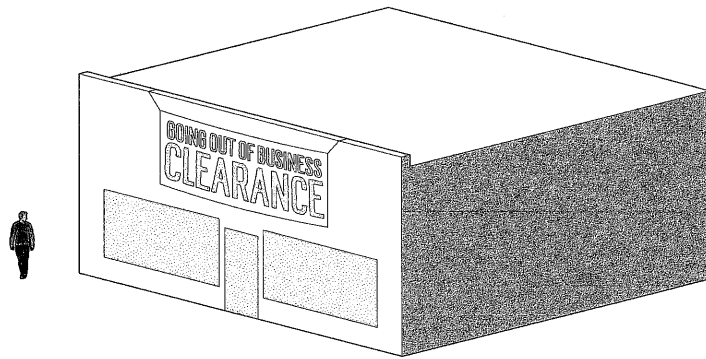
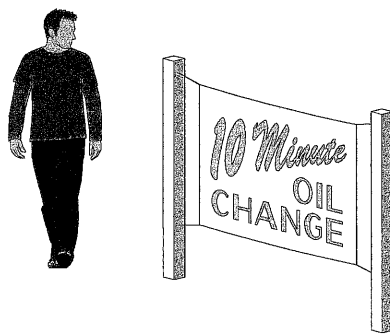

Figure 4. Bench Sign

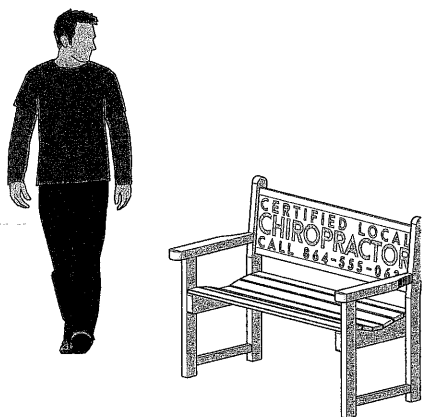

Figure 5. Billboard Sign

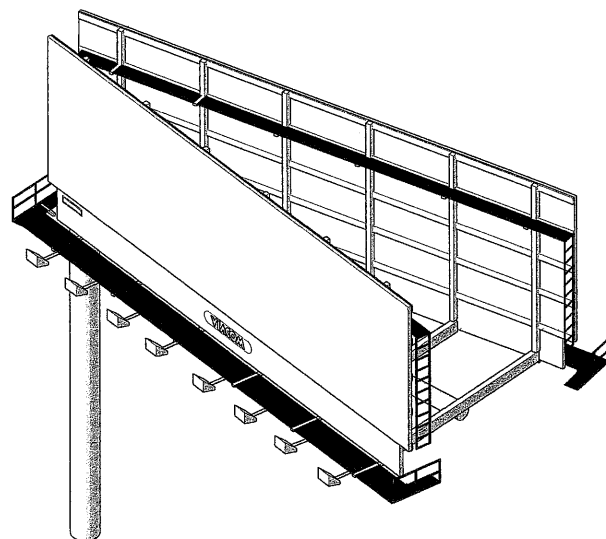

Figure 6. Canopy Sign (attached)

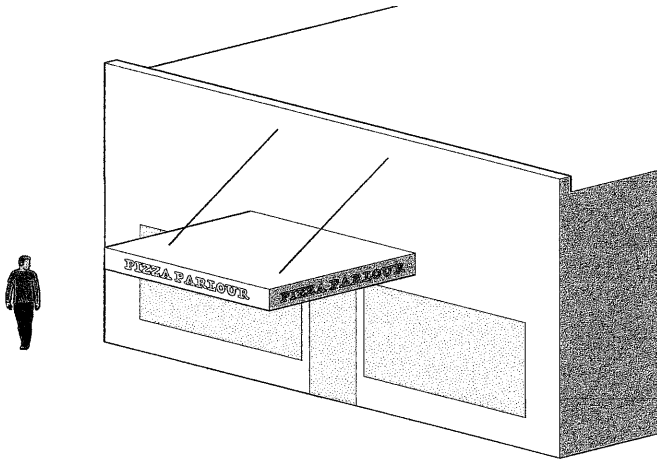

Figure 7. Canopy Sign (detached)

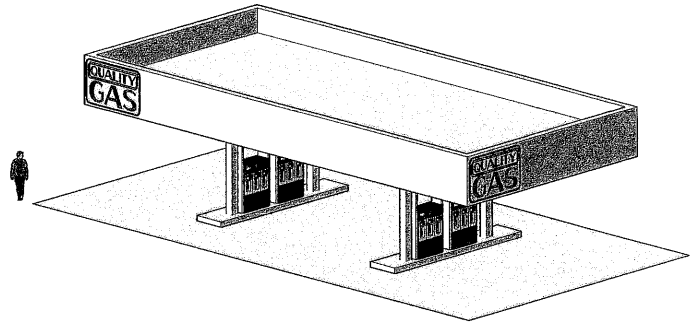

Figure 8. Decorative Post Sign



Figure 9. Decorative Post Sign (suspended)

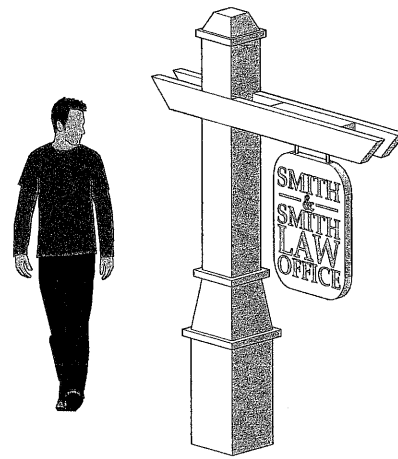

Figure 10. Directory Sign

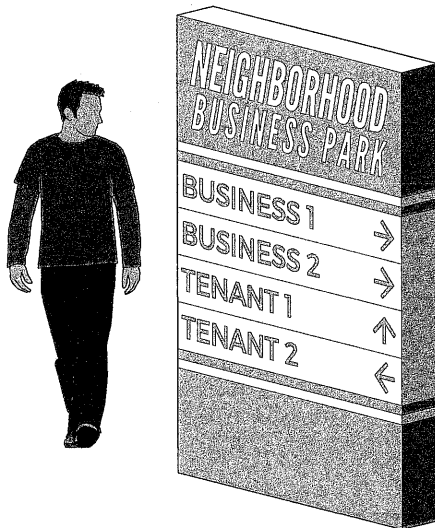

Figure 11. Flag

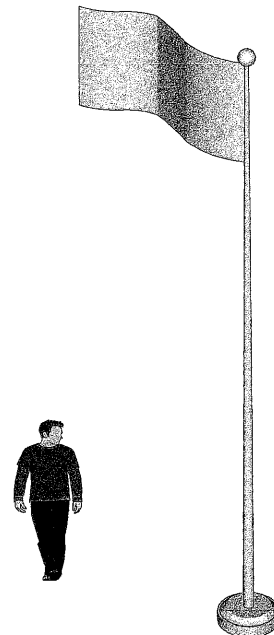

Figure 12. Windfeather Sign



Figure 13. Inflatable Sign

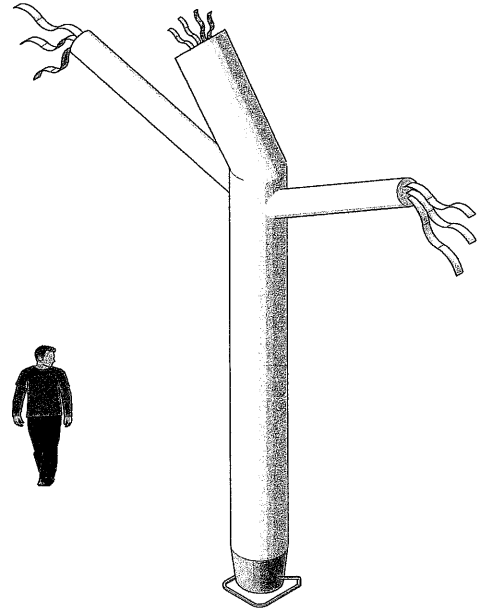
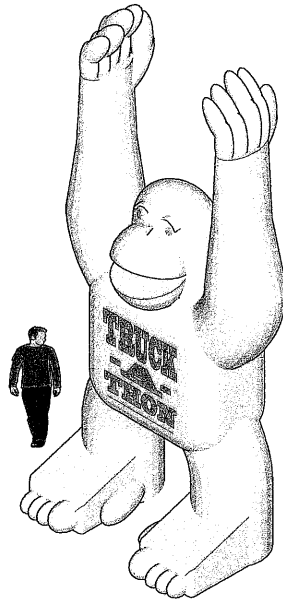

Figure 14. Marquee Sign

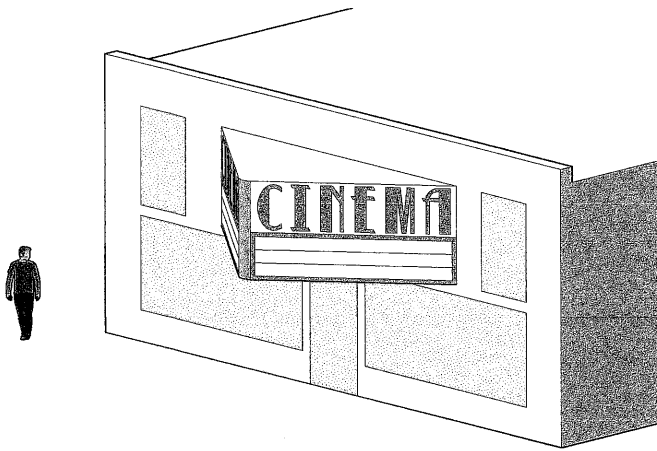

Figure 15. Mobile Sign

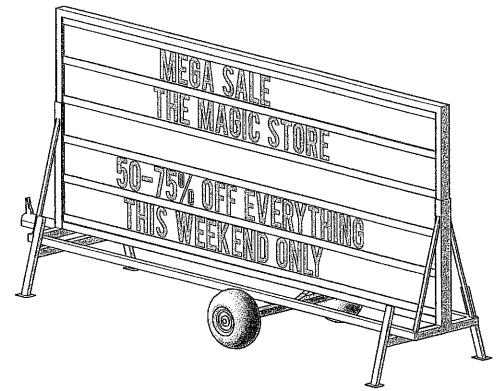

Figure 16. Monument Sign

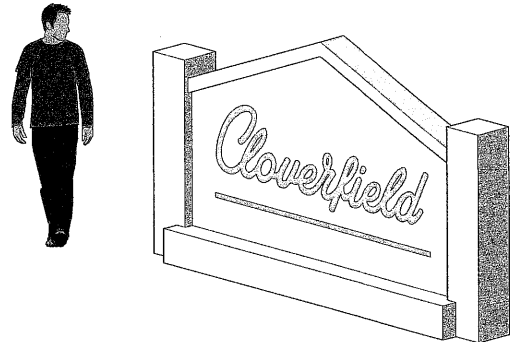
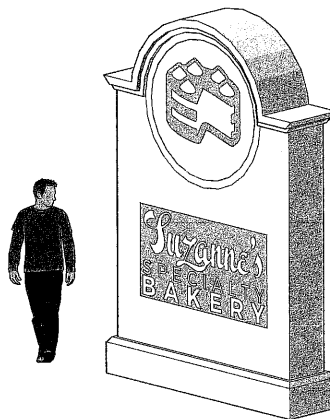
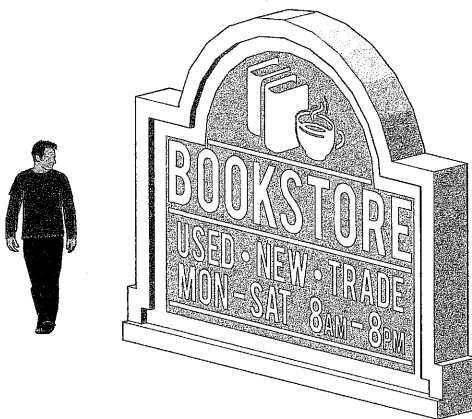

Figure 17. Moveable Sign

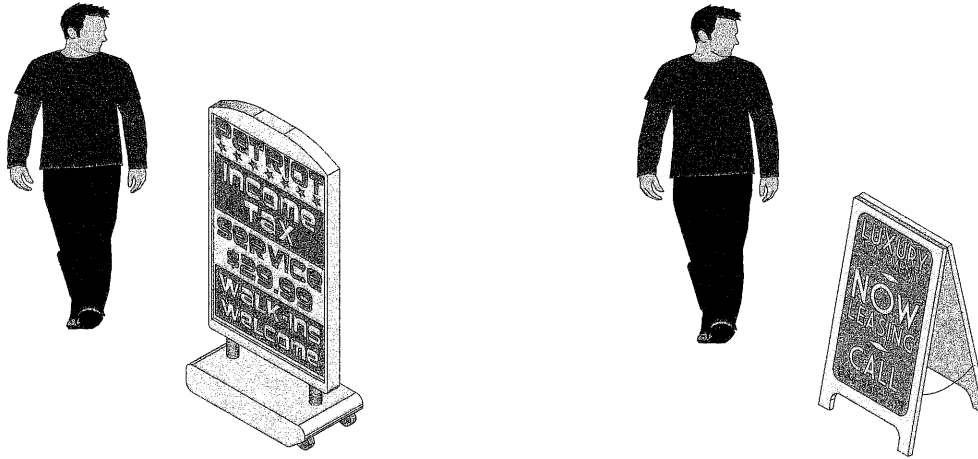

Figure 18. Multiple-faced Sign

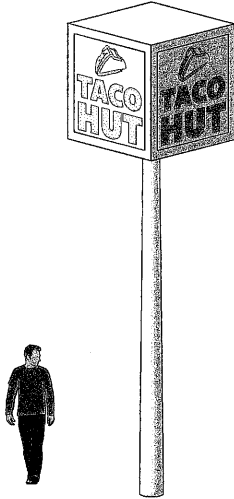

Figure 19. Pennants

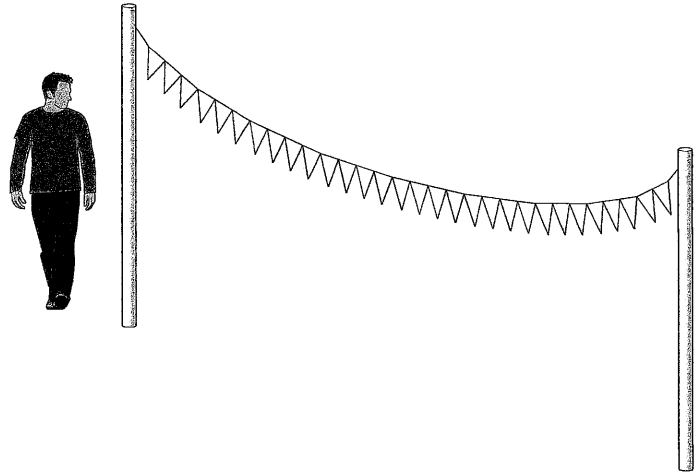

Figure 20. Streamers

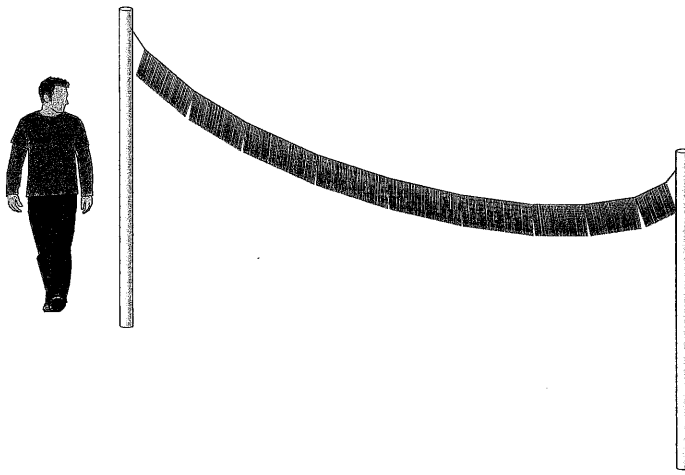

Figure 21. Pole Sign

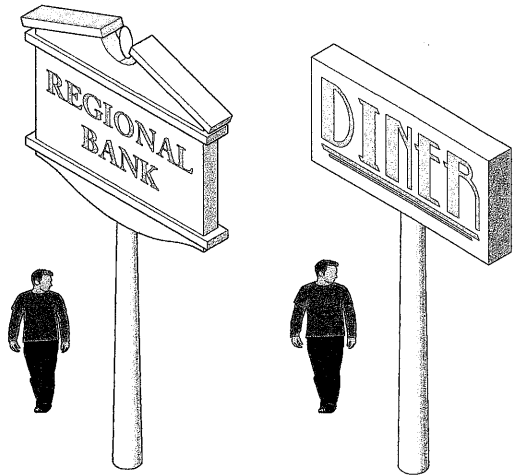

Figure 22. Projecting Sign

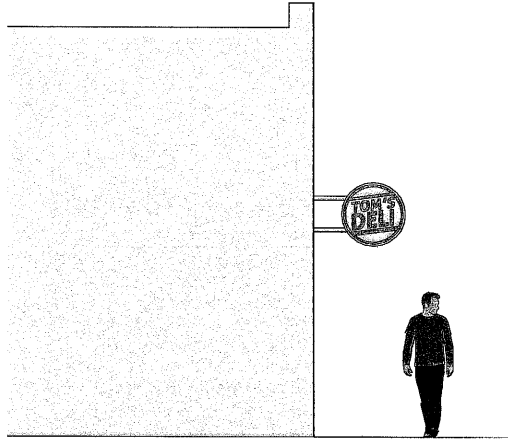

Figure 23. Pylon Sign

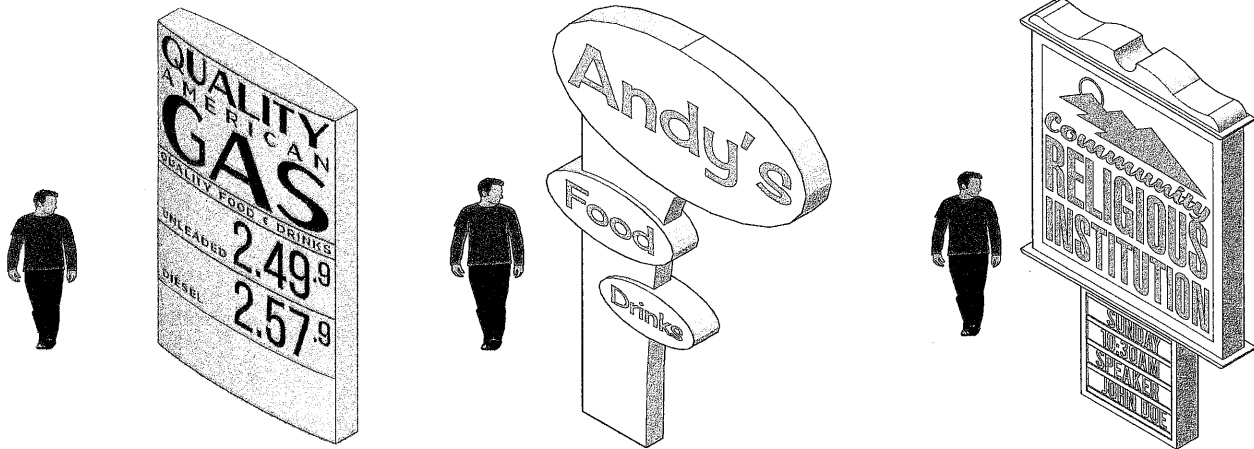

Figure 24. Roof Sign

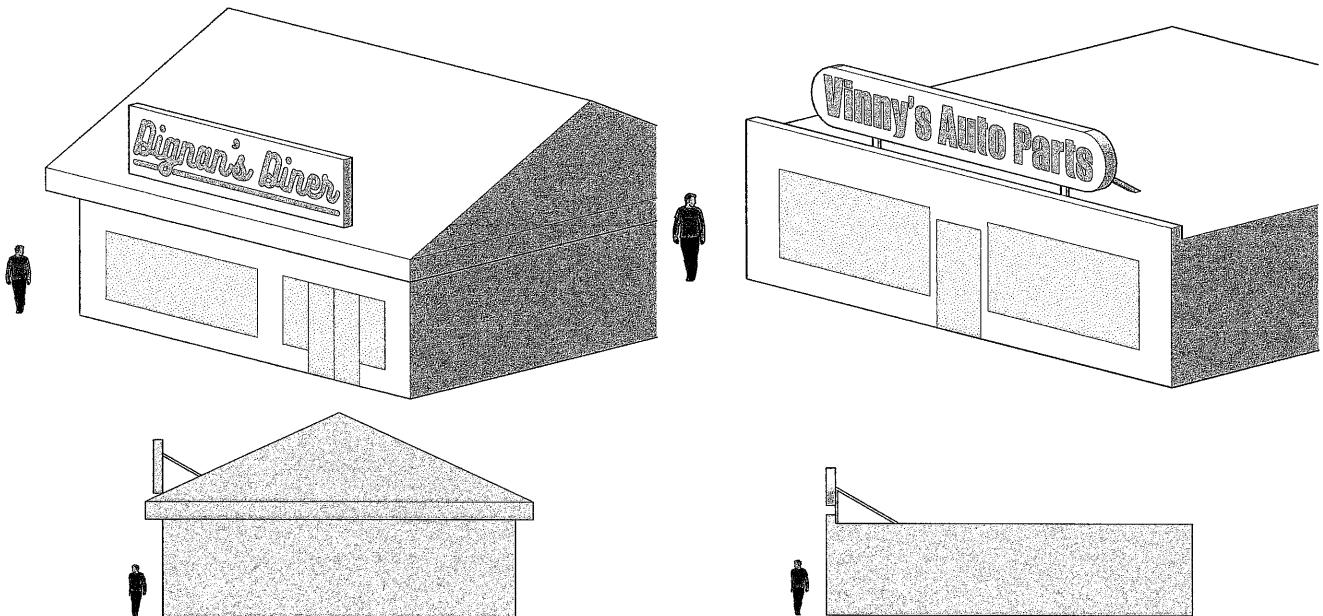

Figure 25. Under canopy/awning Sign

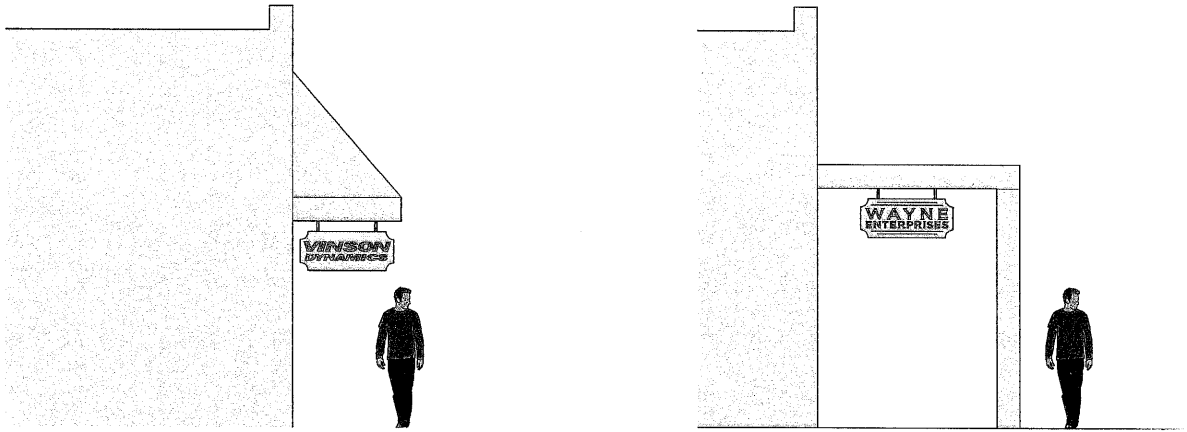

Figure 26. V-Sign

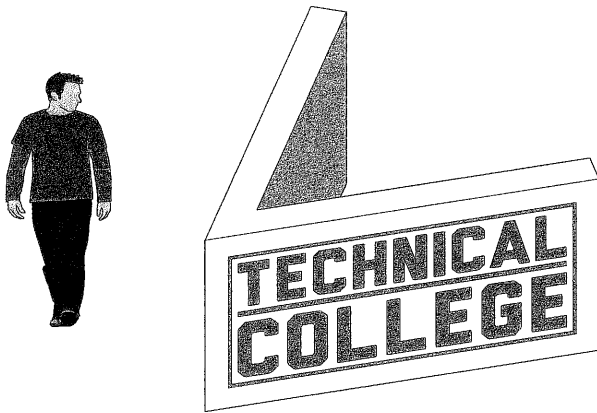

Figure 27. Wall Sign

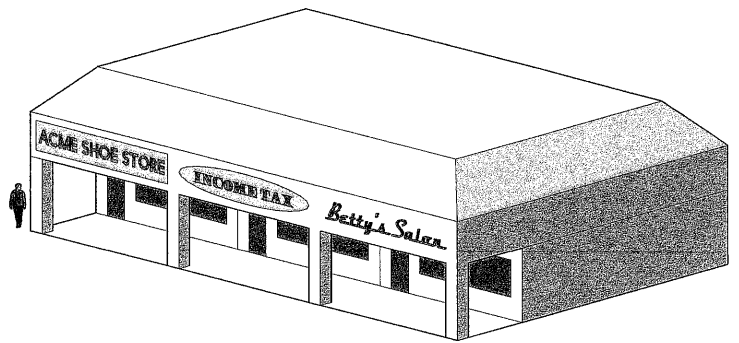

Figure 28. Window Sign

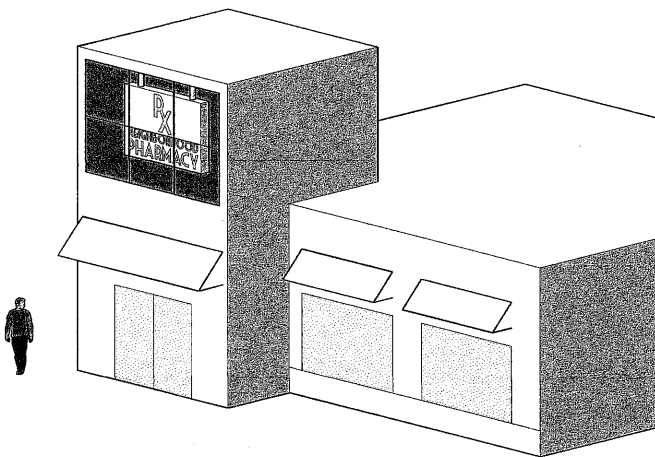
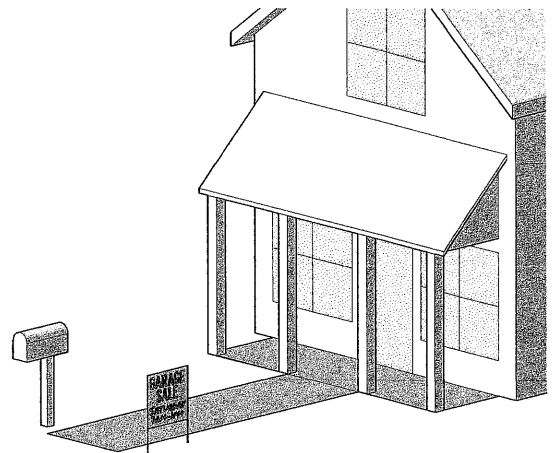

Figure 29. Yard Sign



Appendix B:
Sign Area Computational Methodology

Permitted Freestanding Signs: Monument

Example 1

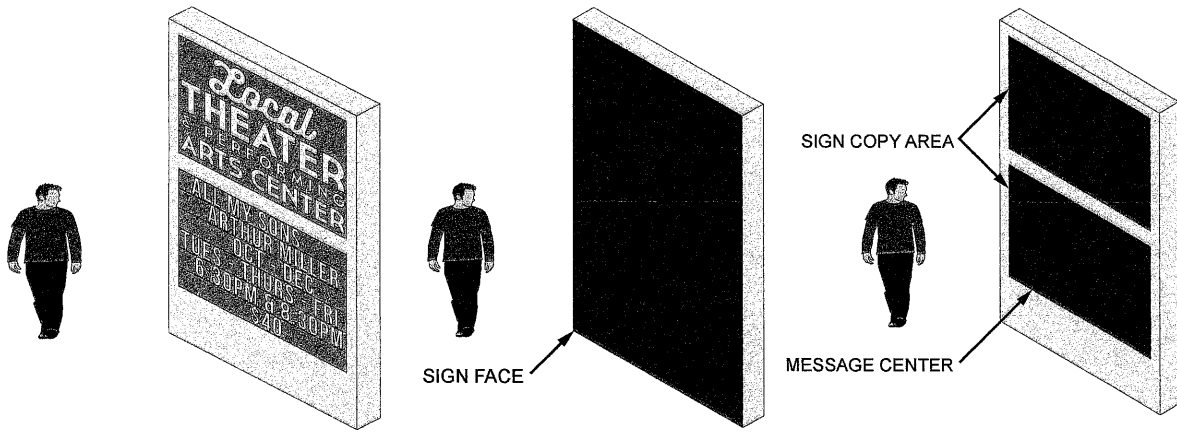

Example 2

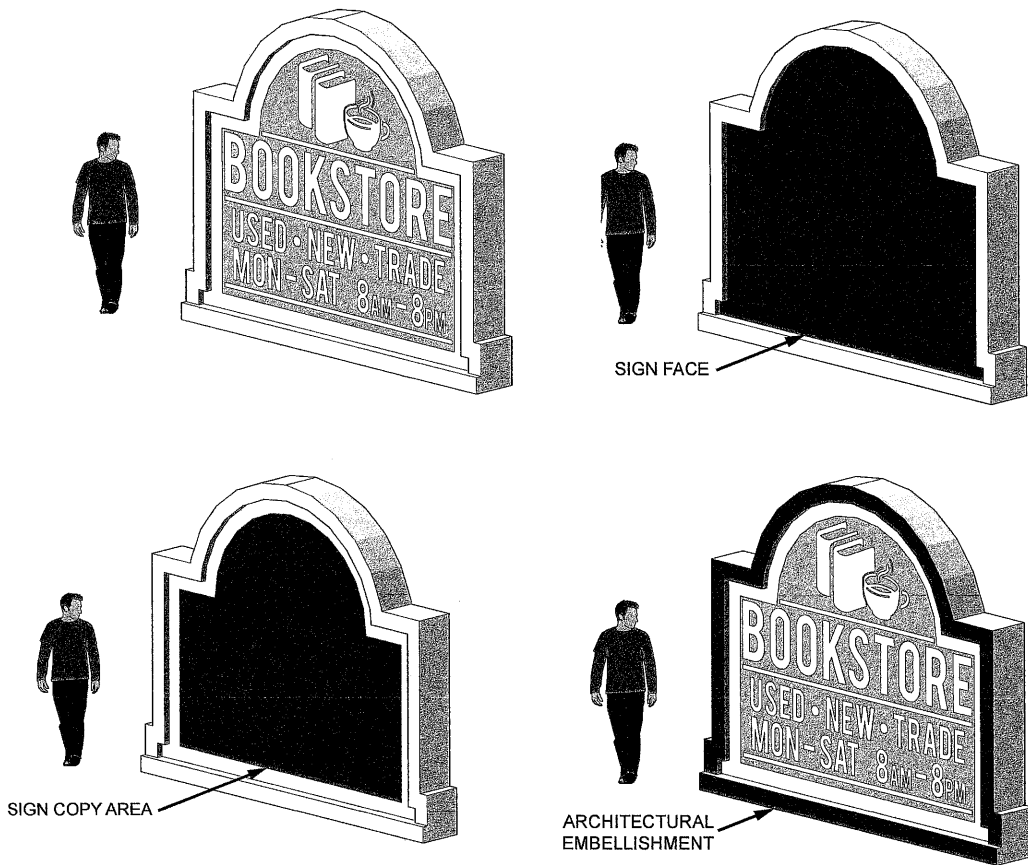

Permitted Freestanding Sign: Multiple Faced Sign

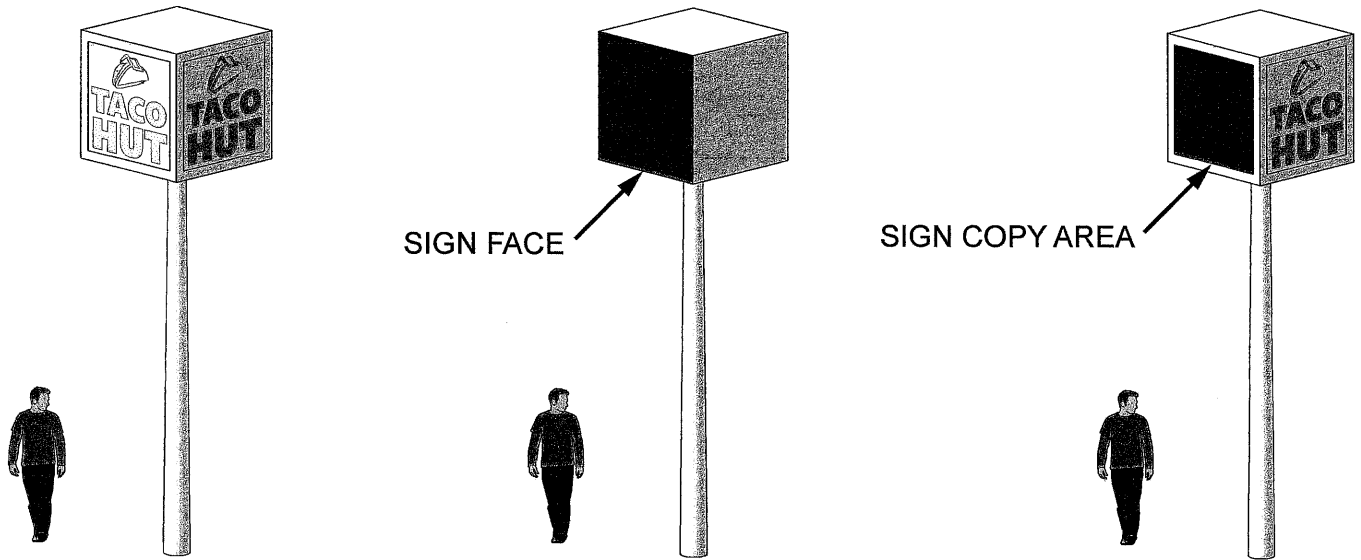

Permitted Freestanding Signs: Decorative Post Sign

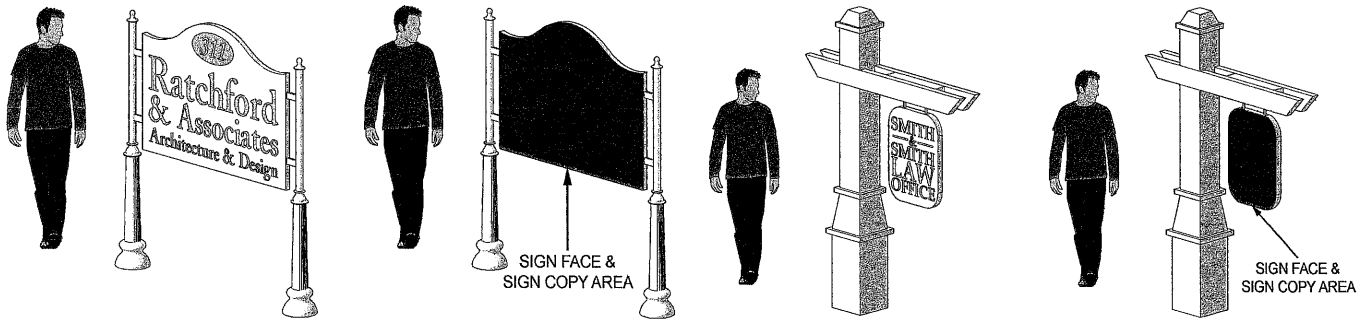

Permitted Freestanding Signs: V-Sign

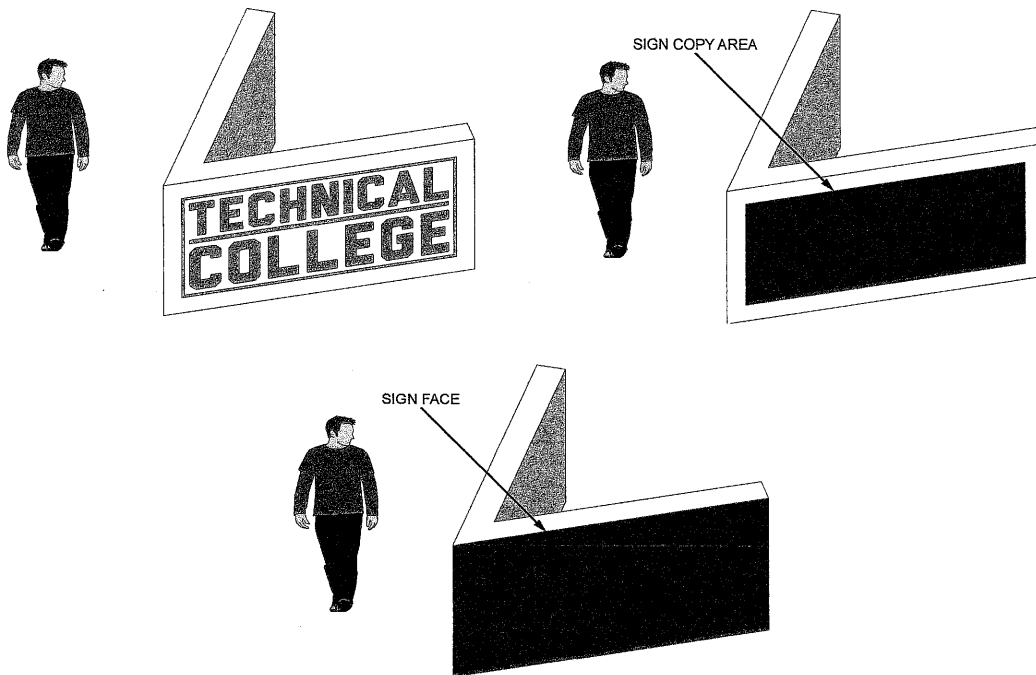

Permitted Freestanding Sign: Pylon Sign

Example 1

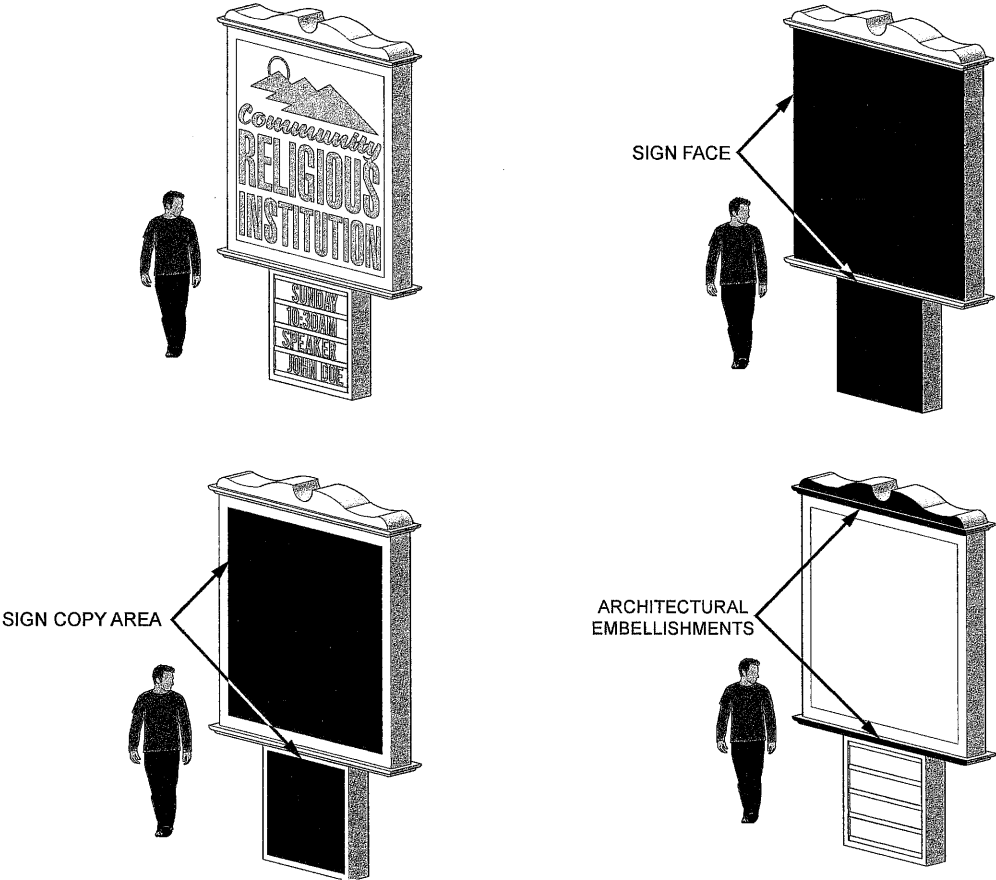

Example 2

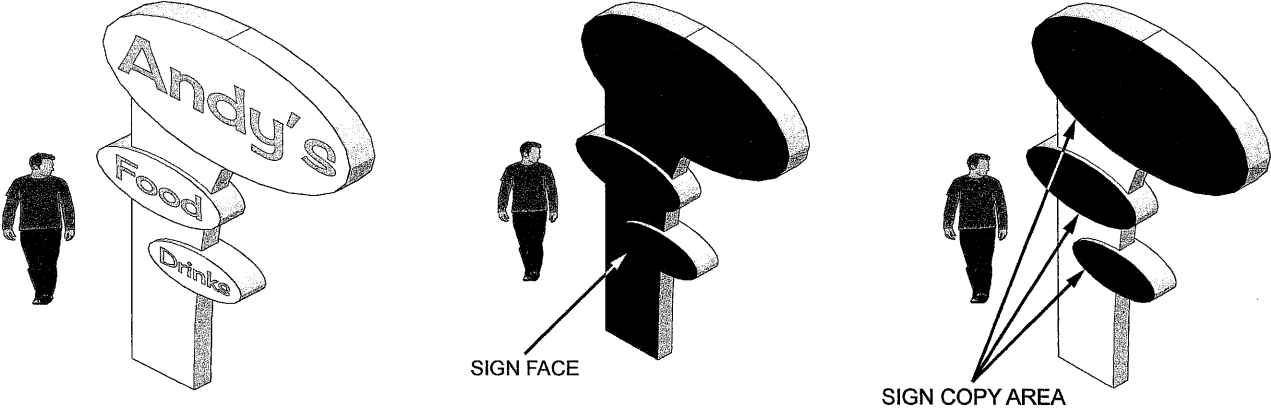

All other signs are measured by the Sign Copy Area

Wall Sign

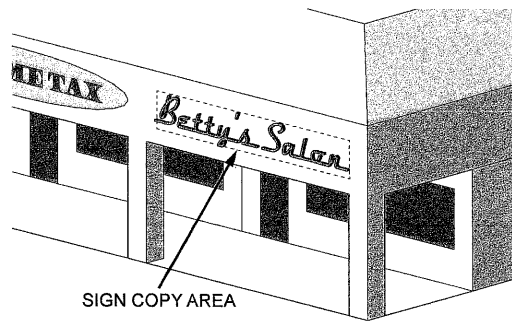
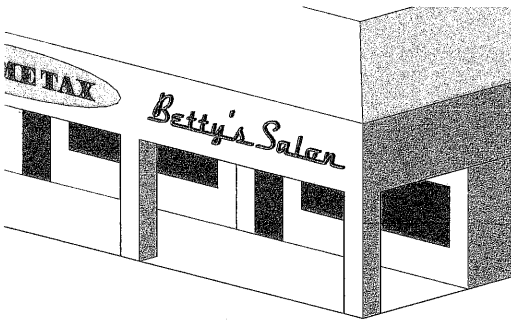
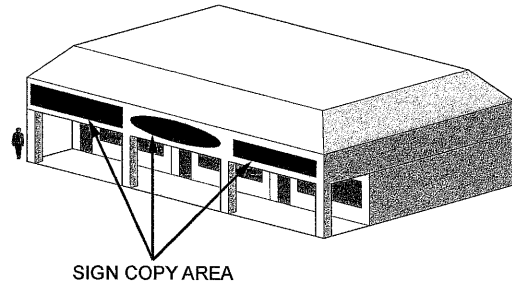
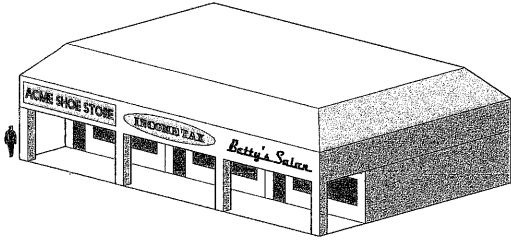

Betty's Salon

SIGN COPY AREA

Under canopy/awning signs

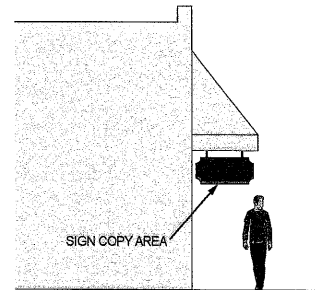
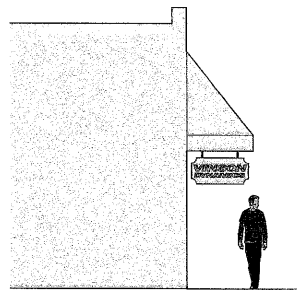
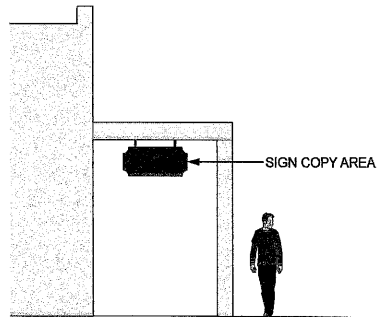

Appendix C:
Scenic Corridors

Greenville County Scenic Corridors

Legend

-  Scenic Corridors
-  Municipal Boundary

