

AREA & ROADWAY LIGHTING

VLL SERIES - LED

Luminaire

Diecast aluminum assembly with minimum wall thickness of 0.150". Integral cooling fins surround the electrical compartment. LED Module mounting area is cast to within a 0.003" surface flatness variance for maximum surface contact and thermal conductivity from the LED modules to the radiating fins. Passive radiating fins above the LED Optics provide superior thermal management and long LED life. The optical and electrical compartments are integrated with the support arm to create one assembly. Hinged driver compartment cover provides access to the drivers and wiring.

PLED™ Optics

Emitters (LED's) are arrayed on a metal core PCB panel with each emitter located on a copper thermal transfer pad and enclosed by an LED refractor. LED optics completely seal each individual emitter to meet an IP66 rating. In asymmetric distributions, a micro-reflector inside the refractor re-directs the house side emitter output towards the street side and functions as a house side shielding element. Refractors are injection molded optical acrylic. Each LED refractor is sealed to the PCB over an emitter and all refractors are retained by an aluminum frame. Any one Panel, or group of Panels in a luminaire, have the same optical pattern. LED refractors produce standard and specialized street, site, and area distributions. All distributions are Zero Uplight (U0), Full-Cutoff and meet Dark Sky requirements. Panels are field replaceable and field rotatable in 90° increments.

LED Emitters

High Power White LED's are driven between 350mA and 1400mA for a maximum output of 4 Watts nominal per LED. LED's are available standard in CCT's of Warm White (2700K & 3000K), Neutral White (4000K), or Cool White (5000K). All Standard LED's have a minimum of 70 CRI. Consult Factory for other LED options. LED Lumen Maintenance of L93 at 100,000 hours up to 1050mA drive current and 60,000 hours at 1225mA and 1400mA drive current (TM-21 calculated at 6x Test Time).

True Amber LED's

TRA-True Amber LED's emit light in a narrow amber spectral bandwidth centered on 585-590nm. True Amber has negligible blue light and is suitable for wildlife.

LED Driver(s)

Constant current electronic with a power factor of >.90 and a minimum operating temperature of -40°F/-40°C. Driver(s) is/are UL and cUL recognized and mounted directly against the Electrical Housing to facilitate thermal transfer, held down by universal clamps to facilitate easy removal. In-line terminal blocks facilitate wiring between the driver and optical arrays. Drivers accept an input of 120-277V, 50/60Hz (UNV) or 347V-480V, 50,60Hz. 0 - 10V dimmable driver is standard. Driver has a minimum of 3KV internal surge protection. Luminaire supplied with 20KV surge protector for field accessible installation.)

Finish

Electrostatically applied TGIC Polyester Powder Coat on substrate prepared with 20 PSI power wash at 140°F. Four step media blast and iron phosphate pretreatment for protection and paint adhesion. 400°F bake for maximum hardness and durability.

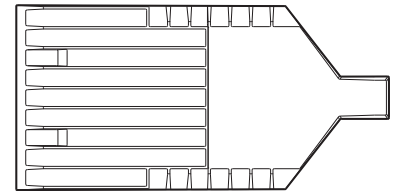
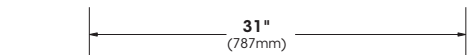

VLL

TOP VIEW

FRONT VIEW

SIDE VIEW

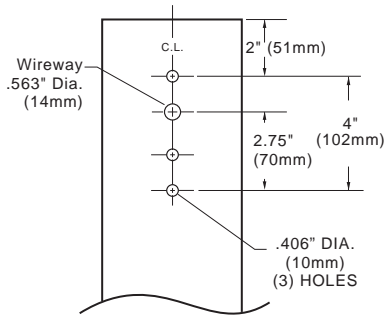

2023248

SPECIFICATIONS

POLE DRILLING TEMPLATE

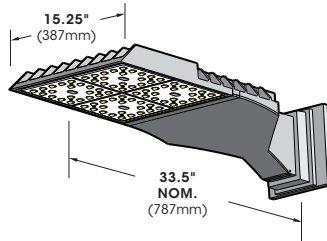

WALL MOUNT



Extruded aluminum arm and cast aluminum Wall Bracket assembly provided with built in gasketed Wire access for Fixture/supply Wire connection.

EPA & WEIGHT

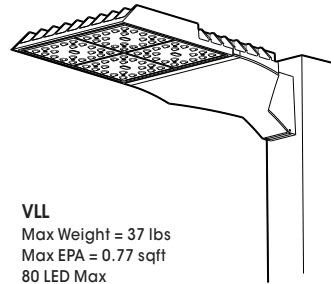

VLL
Max Weight = 37 lbs
Max EPA = 0.77 sqft
80 LED Max

PLED™ MODULES

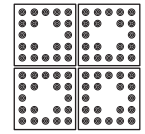

80 LED Module

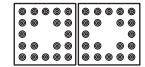

40 LED Module

MOUNT PLATE

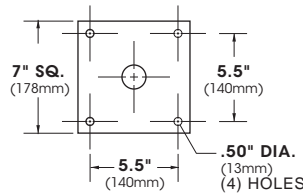

ORDERING INFORMATION

Spec/Order Example: VLL/PLED-III/174W-80-700/30K/UNV/TPR

Luminaire	Optics	LED Mode	Voltage	Mounting	Finish	Options	
Luminaire	Optics	LED	Voltage	Mounting	Finish	Options	
<input type="checkbox"/> VLL	<p>PLED™ Distribution Type</p> <ul style="list-style-type: none"> <input type="checkbox"/> Type II PLED-II <input type="checkbox"/> Type II Front Row PLED-II-FR <input type="checkbox"/> Type II Median Illuminator PLED-II-ML <input type="checkbox"/> Type III Med. PLED-III <input type="checkbox"/> Type III Wide PLED-III-W <input type="checkbox"/> Type IV PLED-IV <input type="checkbox"/> Type IV PLED-IV-FT <input type="checkbox"/> Type V Narrow PLED-VSQ-N <input type="checkbox"/> Type V Med. PLED-V-SQ-M <input type="checkbox"/> Type V Wide PLED-V-SQ-W 	<p>Watts - # of LED's - Drive Current(mA)</p> <p>Standard White LED's</p> <ul style="list-style-type: none"> <input type="checkbox"/> 43W-40-350 <input type="checkbox"/> 65W-40-525 <input type="checkbox"/> 87W-40-700 <input type="checkbox"/> 111W-40-875 <input type="checkbox"/> 135W-40-1050 <input type="checkbox"/> 159W-40-1225 <input type="checkbox"/> 174W-80-700 <input type="checkbox"/> 222W-80-875 <input type="checkbox"/> 270W-80-1050 <input type="checkbox"/> 318W-80-1225 <input type="checkbox"/> 366W-80-1400 <p>True Amber LED's</p> <ul style="list-style-type: none"> <input type="checkbox"/> 33W-40-350 <input type="checkbox"/> 51W-40-525 <input type="checkbox"/> 67W-80-350 <input type="checkbox"/> 101W-80-525 	<p>Color Temp - CCT</p> <ul style="list-style-type: none"> <input type="checkbox"/> 27K (2700K) <input type="checkbox"/> 30K (3000K) <input type="checkbox"/> 40K (4000K) <input type="checkbox"/> 50K (5000K) <p>Consult Factory for Other LED Color, CCT, & CRI Options</p> <ul style="list-style-type: none"> <input type="checkbox"/> TRA True Amber 	<ul style="list-style-type: none"> <input type="checkbox"/> UNV (120 to 277) <input type="checkbox"/> 347 <input type="checkbox"/> 480 	<p>Arm Mount</p> <ul style="list-style-type: none"> <input type="checkbox"/> 1 <input type="checkbox"/> 2-180 <input type="checkbox"/> 2-90 <input type="checkbox"/> 3-90 <input type="checkbox"/> 3-120 <input type="checkbox"/> 4-90 <p>Wall Mount</p> <ul style="list-style-type: none"> <input type="checkbox"/> WM <p>WM - Wall Mount provided with mounting bracket and cover.</p>	<p>Standard Textured Finish</p> <ul style="list-style-type: none"> <input type="checkbox"/> Black RAL-9005-T <input type="checkbox"/> White RAL-9003-T <input type="checkbox"/> Grey RAL-7004-T <input type="checkbox"/> Dark Bronze RAL-8019-T <input type="checkbox"/> Green RAL-6005-T <p>Premium Finishes</p> <ul style="list-style-type: none"> <input type="checkbox"/> Rust <input type="checkbox"/> Patina Copper PC <p>For smooth finish replace suffix "T" with suffix "S" (Example: RAL-9500-S)</p> <p>Consult factor for custom colors</p>	<ul style="list-style-type: none"> <input type="checkbox"/> Internal House Side Shield inc. LED Count (Example: HS-PLED/48) HS-PLED <input type="checkbox"/> External Glare Shield 4 Sided EGS4 <input type="checkbox"/> External Glare Shield 3 Sided Rear Wedge EGS3W <input type="checkbox"/> Round Pole Adapter RPA <input type="checkbox"/> Twist Lock Receptacle Only TPR <input type="checkbox"/> 7-Pin Twist Lock Receptacle Only TPR7 <input type="checkbox"/> High-Low Dimming for Switch by Others/Select Levels 50/100 or 25/100 (Example: HLSW/25) HLSW <input type="checkbox"/> Photo Cell + Voltage (Example: PC120V) PC+V <input type="checkbox"/> Single Fuse + Voltage (Example: SF277) SF+V <input type="checkbox"/> Double Fuse + Voltage (Example: DF208) DF+V <input type="checkbox"/> Blue-Tooth Programmable Photo/Motion Sensor (Factory - Motion 50/100; Photo 75fc) MS-F311

OPTIONS

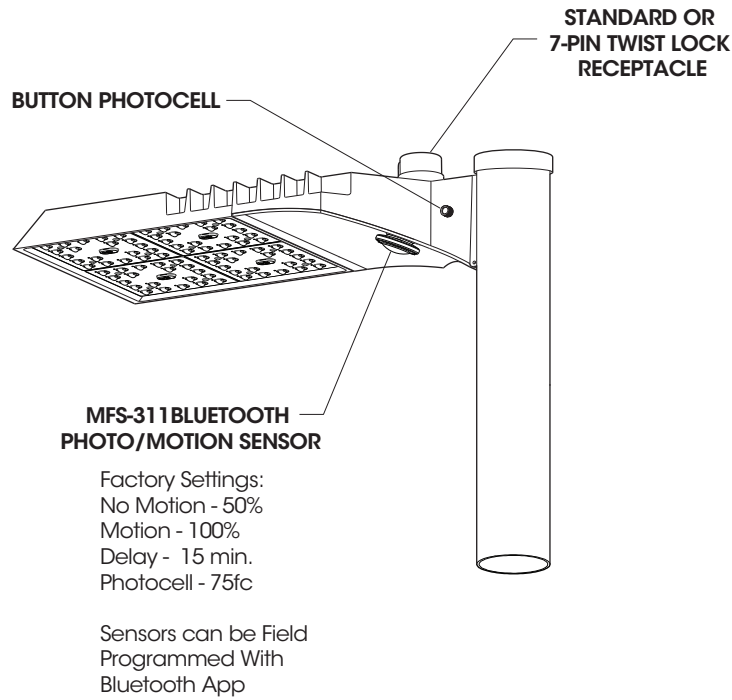

High Low Dimming For Switches (HLSW)

The HLSW is a Small Electronic Switch which Provides High Low Dimming Control Through the LED Driver's 0-10V Control. Switching is Done by Adding a Secondary AC Switched Hot Trigger Line to the HLSW in Addition to the Normal AC Power Line. When the Secondary Trigger Line is Powered, the Fixture will go to 100% Dimming. With no Power to the Trigger, the Fixture will operate at 50% or 25% Dimming. Switches for the Trigger Line can be a Normal AC Switch/Breaker or Timed Switch/Breaker.

Wireless and Other Fixture Controls

Contact Factory for Wireless and Other Fixture Controls and Recommendations. Most Controls Can be Integrated and Factory Installed.

External Glare Shields

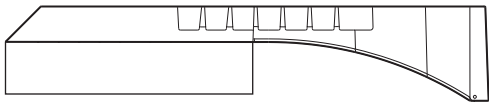

EGS4 - 4 Sided Shield - 3" Deep

Minimum Cutoff = 12°
Average Cutoff = 23°

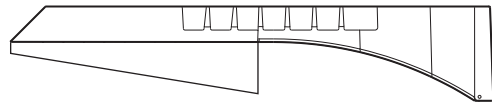

EGS3W - 3 Sided Shield - 3" Rear Depth

Minimum Rear Cutoff = 12°
Average Rear Cutoff = 23°
Minimum Side Cutoff = 4°
Average Side Cutoff = 16°

Glare Shields are rotatable on VLL. Shields are Powdercoated Flat Black. Consult factory for custom applications.

INSTALLATION DETAIL

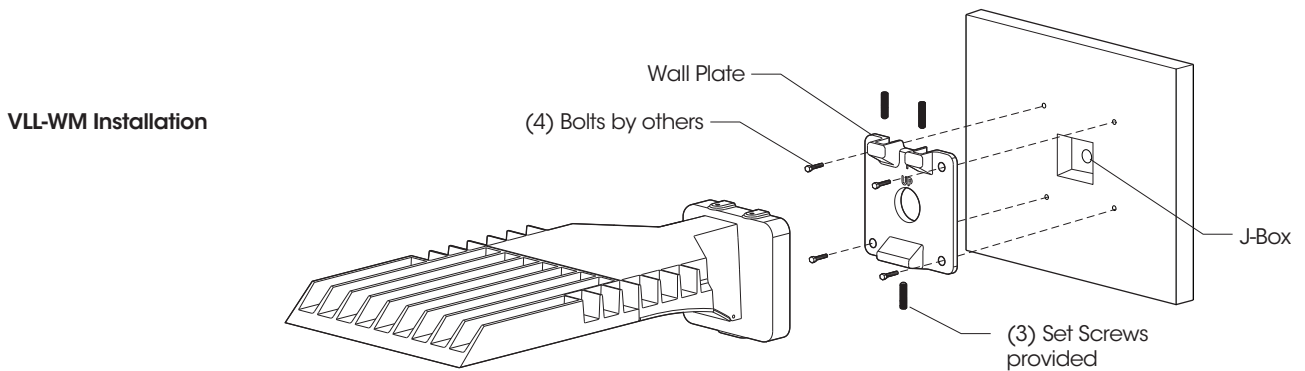
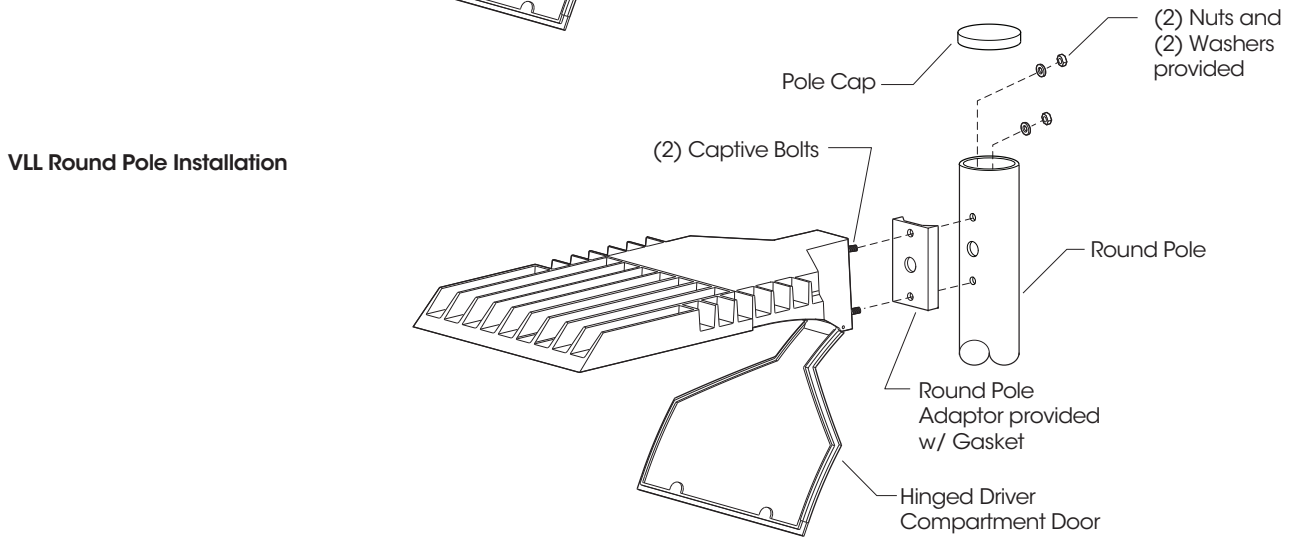
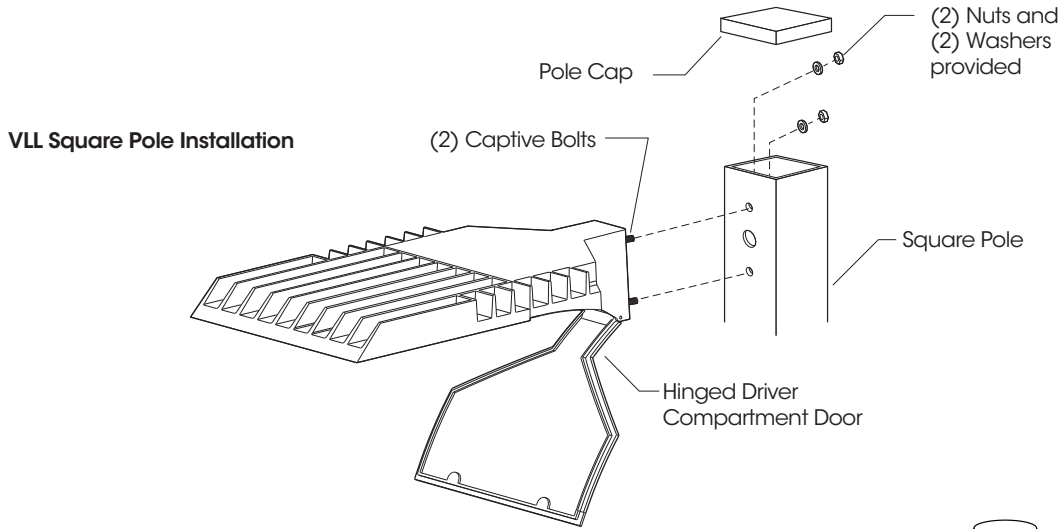

PHOTOMETRIC DATA GUIDE - LM-80 LUMEN MAINTENANCE

LED LUMEN MAINTENANCE (350mA to 1050mA)		
LED Life / Operating Hours	Lumen Depreciation	Lumen Depreciation Scale Factor
60,000	L96	0.96x
100,000 (6X LED Test Hrs)	L93	0.93x
150,000 (Theoretical)	L89	0.90x
200,000 (Theoretical)	L86	0.87x

TM-21 6x Test Time Dictates that L93 > 100,000 Hours.

LED LUMEN MAINTENANCE (1225mA & 1400mA)		
LED Life / Operating Hours	Lumen Depreciation	Lumen Depreciation Scale Factor
60,000 (6X LED Test Hrs)	L93	0.93x
100,000 (Theoretical)	L89	0.89x
150,000 (Theoretical)	L84	0.84x
200,000 (Theoretical)	L80	0.80x

TM-21 6x Test Time Dictates that L93 > 60,000 Hours.

Lumen Depreciation Calculations Done in Accordance With IESNA TM-21 & LM-80 (25°C Ambient)

ELECTRICAL DATA GUIDE - AMPERAGE CHARTS

Standard White LED's

# of LEDs	mA	System Watts	120V	208V	277V	347V	480V
40	350	43	0.36	0.21	0.15	0.12	0.09
40	525	65	0.54	0.31	0.23	0.19	0.14
40	700	87	0.72	0.42	0.31	0.25	0.18
40	875	111	0.92	0.53	0.40	0.32	0.23
40	1050	135	1.12	0.65	0.49	0.39	0.28
40	1225	159	1.32	0.76	0.57	0.46	0.33
80	700	174	1.45	0.83	0.63	0.50	0.36
80	875	222	1.85	1.06	0.80	0.64	0.46
80	1050	270	2.25	1.30	0.97	0.78	0.56
80	1225	318	2.65	1.53	1.15	0.92	0.66
80	1400	366	3.05	1.76	1.32	1.06	0.76

True Amber LED's

# of LEDs	mA	System Watts	120V	208V	277V	347V	480V
40	350	33	0.28	0.16	0.12	0.10	0.07
40	525	51	0.43	0.25	0.18	0.15	0.11
80	350	67	0.56	0.32	0.24	0.19	0.14
80	525	101	0.84	0.49	0.36	0.29	0.21

PHOTOMETRIC DATA GUIDE - ISOFOOTCANDLE PLOTS

VLL-PLED-80LED-700mA-40K - 25' Pole Height

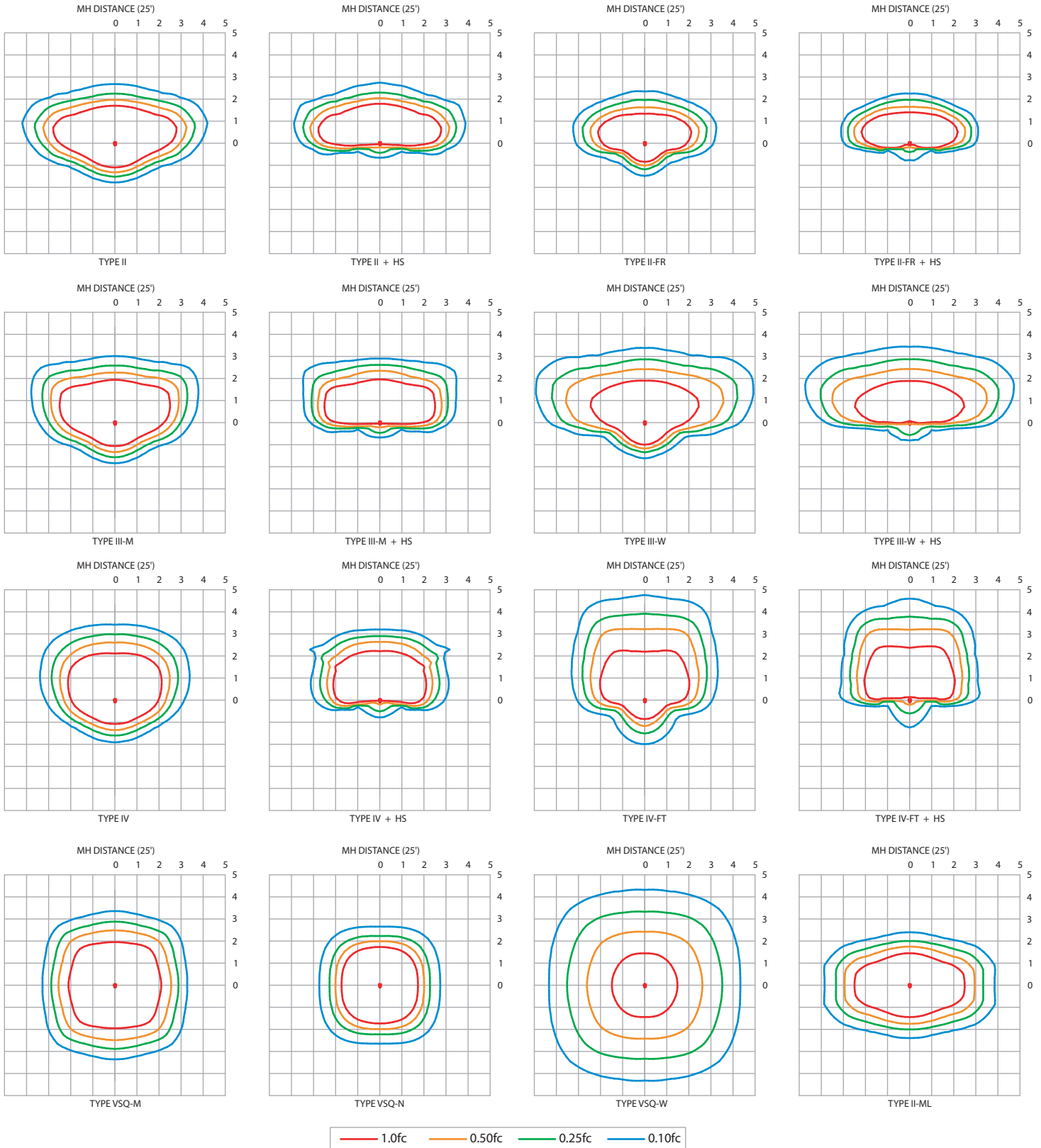

IES File downloads for this product can be found at www.usaltg.com/downloads/asr.html

PHOTOMETRIC DATA GUIDE - LUMEN TABLES (VLL-PLD)

LED Count	Drive Current (mA)	System Watts	Dist'n Type	27K (2700K - 70CRI)			30K (3000K - 70CRI)			40K (4000K - 70CRI)			50K (5000K - 70CRI)			System Watts	TRA (590nm)							
				LUMENS	LPW	BUG RATING	LUMENS	LPW	BUG RATING	LUMENS	LPW	BUG RATING	LUMENS	LPW	BUG RATING		LUMENS	LPW	BUG RATING					
40	350	43	II	6500	152	B2-U0-G2	6782	158	B2-U0-G2	7065	165	B2-U0-G2	7348	171	B2-U0-G2	33.0	2309	70	B1-U0-G1					
			II-FR	6544	153	B2-U0-G1	6828	159	B2-U0-G1	7113	166	B2-U0-G1	7397	172	B2-U0-G1		2325	70	B1-U0-G0					
			II-ML	6500	152	B3-U0-G3	6783	158	B3-U0-G3	7065	165	B3-U0-G3	7348	171	B3-U0-G3		2309	70	B1-U0-G1					
			III-M	6614	154	B2-U0-G2	6901	161	B2-U0-G2	7189	168	B2-U0-G2	7476	174	B2-U0-G2		2349	71	B1-U0-G1					
			III-W	6141	143	B1-U0-G2	6408	149	B1-U0-G2	6675	156	B1-U0-G2	6942	162	B1-U0-G2		2182	66	B1-U0-G1					
			IV	6564	153	B2-U0-G2	6849	160	B2-U0-G2	7135	166	B2-U0-G2	7420	173	B2-U0-G2		2332	71	B1-U0-G1					
			IV-FT	5979	139	B1-U0-G2	6239	145	B1-U0-G2	6499	152	B1-U0-G2	6759	158	B1-U0-G2		2124	64	B1-U0-G1					
			VSQ-N	6860	160	B2-U0-G1	7159	167	B2-U0-G1	7457	174	B2-U0-G1	7755	181	B2-U0-G1		2438	74	B1-U0-G0					
			VSQ-M	6727	157	B3-U0-G1	7020	164	B3-U0-G1	7313	170	B3-U0-G1	7605	177	B3-U0-G2		2390	72	B2-U0-G1					
			VSQ-W	6567	153	B3-U0-G2	6852	160	B3-U0-G2	7138	166	B3-U0-G2	7423	173	B3-U0-G2		2333	71	B2-U0-G1					
			II-HS	4754	111	B1-U0-G2	4961	116	B1-U0-G2	5167	120	B1-U0-G2	5374	125	B1-U0-G2		1689	51	B0-U0-G0					
			II-FR-HS	4836	113	B0-U0-G1	5046	118	B0-U0-G1	5256	123	B0-U0-G1	5466	127	B0-U0-G1		1718	52	B0-U0-G0					
			III-M-HS	4810	112	B0-U0-G2	5019	117	B0-U0-G2	5228	122	B0-U0-G2	5437	127	B0-U0-G2		1708	52	B0-U0-G1					
			III-W-HS	4708	110	B0-U0-G2	4912	115	B0-U0-G2	5117	119	B0-U0-G2	5321	124	B0-U0-G2		1673	51	B0-U0-G1					
			IV-HS	4968	116	B0-U0-G2	5184	121	B0-U0-G2	5400	126	B0-U0-G2	5616	131	B0-U0-G2		1764	53	B0-U0-G1					
			IV-FT-HS	4695	109	B0-U0-G2	4899	114	B0-U0-G2	5103	119	B0-U0-G2	5307	124	B0-U0-G2		1668	51	B0-U0-G1					
			40	525	65	II	9340	144	B2-U0-G2	9746	150	B2-U0-G2	10152	157	B2-U0-G2		10559	163	B2-U0-G2	51.0	2715	53	B1-U0-G1	
						II-FR	9403	145	B2-U0-G1	9812	151	B2-U0-G1	10221	158	B2-U0-G1		10630	164	B2-U0-G1		2733	54	B1-U0-G1	
						II-ML	9341	144	B3-U0-G3	9747	150	B3-U0-G3	10153	157	B3-U0-G3		10559	163	B3-U0-G3		2715	53	B1-U0-G1	
						III-M	9504	147	B2-U0-G2	9917	153	B2-U0-G2	10330	159	B2-U0-G2		10743	166	B2-U0-G2		2762	54	B1-U0-G1	
III-W	8824	136				B2-U0-G3	9208	142	B2-U0-G3	9592	148	B2-U0-G3	9976	154	B2-U0-G3	2565	50	B1-U0-G1						
IV	9433	146				B2-U0-G2	9843	152	B2-U0-G2	10253	158	B2-U0-G2	10663	165	B2-U0-G2	2742	54	B1-U0-G1						
IV-FT	8592	133				B2-U0-G2	8966	138	B2-U0-G2	9340	144	B2-U0-G2	9713	150	B2-U0-G2	2497	49	B1-U0-G1						
VSQ-N	9858	152				B3-U0-G1	10287	159	B3-U0-G1	10716	165	B3-U0-G1	11144	172	B3-U0-G1	2866	56	B1-U0-G0						
VSQ-M	9667	149				B3-U0-G2	10088	156	B3-U0-G2	10508	162	B3-U0-G2	10928	169	B4-U0-G2	2809	55	B2-U0-G1						
VSQ-W	9436	146				B4-U0-G3	9846	152	B4-U0-G3	10257	158	B4-U0-G3	10667	165	B4-U0-G3	2743	54	B2-U0-G1						
II-HS	6831	105				B1-U0-G2	7128	110	B1-U0-G2	7425	115	B1-U0-G2	7722	119	B1-U0-G2	1985	39	B0-U0-G1						
II-FR-HS	6949	107				B1-U0-G1	7251	112	B1-U0-G1	7553	117	B1-U0-G1	7855	121	B1-U0-G1	2020	40	B0-U0-G0						
III-M-HS	6911	107				B0-U0-G2	7212	111	B0-U0-G2	7512	116	B1-U0-G2	7813	121	B1-U0-G2	2009	39	B0-U0-G1						
III-W-HS	6764	104				B0-U0-G2	7059	109	B0-U0-G2	7353	113	B0-U0-G2	7647	118	B0-U0-G2	1966	39	B0-U0-G1						
IV-HS	7138	110				B0-U0-G2	7449	115	B1-U0-G2	7759	120	B1-U0-G2	8069	125	B1-U0-G2	2075	41	B0-U0-G1						
IV-FT-HS	6746	104				B0-U0-G2	7040	109	B1-U0-G3	7333	113	B1-U0-G3	7626	118	B1-U0-G3	1960	38	B0-U0-G1						
40	700	87				II	11823	136	B2-U0-G2	12337	142	B2-U0-G2	12851	148	B2-U0-G2	13365	154	B2-U0-G2	N/A		N/A			
						II-FR	11903	137	B3-U0-G1	12420	143	B3-U0-G1	12938	149	B3-U0-G1	13455	155	B3-U0-G1						
						II-ML	11824	136	B3-U0-G3	12338	142	B3-U0-G3	12852	148	B3-U0-G3	13366	154	B3-U0-G3						
						III-M	12030	139	B2-U0-G2	12553	145	B2-U0-G2	13076	151	B2-U0-G2	13599	157	B2-U0-G2						
			III-W	11170	129	B2-U0-G3	11656	134	B2-U0-G3	12142	140	B2-U0-G3	12627	145	B2-U0-G3									
			IV	11940	138	B2-U0-G2	12459	144	B2-U0-G2	12978	150	B2-U0-G2	13497	156	B2-U0-G2									
			IV-FT	10876	125	B2-U0-G3	11349	131	B2-U0-G3	11822	136	B2-U0-G3	12295	142	B2-U0-G3									
			VSQ-N	12479	144	B3-U0-G1	13022	150	B3-U0-G1	13564	156	B3-U0-G1	14107	163	B3-U0-G1									
			VSQ-M	12237	141	B4-U0-G2	12769	147	B4-U0-G2	13301	153	B4-U0-G2	13833	159	B4-U0-G2									
			VSQ-W	11945	138	B4-U0-G3	12464	144	B4-U0-G3	12983	150	B4-U0-G3	13502	156	B4-U0-G3									
			II-HS	8647	100	B1-U0-G2	9023	104	B1-U0-G2	9399	108	B1-U0-G2	9775	113	B1-U0-G2									
			II-FR-HS	8797	101	B1-U0-G1	9179	106	B1-U0-G1	9561	110	B1-U0-G1	9944	115	B1-U0-G1									
			III-M-HS	8749	101	B1-U0-G2	9129	105	B1-U0-G2	9510	110	B1-U0-G2	9890	114	B1-U0-G2									
			III-W-HS	8563	99	B1-U0-G2	8935	103	B1-U0-G2	9307	107	B1-U0-G2	9680	112	B1-U0-G3									
			IV-HS	9036	104	B1-U0-G2	9429	109	B1-U0-G2	9822	113	B1-U0-G2	10215	118	B1-U0-G2									
			IV-FT-HS	8540	98	B1-U0-G3	8911	103	B1-U0-G3	9282	107	B1-U0-G3	9653	111	B1-U0-G3									
			40	875	111	II	14169	128	B2-U0-G2	14784	133	B3-U0-G2	15401	139	B3-U0-G2	16017	145	B3-U0-G3		N/A			N/A	
						II-FR	14264	129	B3-U0-G1	14884	134	B3-U0-G2	15504	140	B3-U0-G2	16125	146	B3-U0-G2						
						II-ML	14169	128	B3-U0-G3	14785	133	B4-U0-G4	15401	139	B4-U0-G4	16018	145	B4-U0-G4						
						III-M	14417	130	B2-U0-G2	15043	136	B2-U0-G2	15670	141	B3-U0-G2	16297	147	B3-U0-G3						
III-W	13386	121				B2-U0-G3	13968	126	B2-U0-G3	14550	131	B2-U0-G3	15132	137	B2-U0-G3									
IV	14309	129				B2-U0-G2	14931	135	B2-U0-G2	15553	140	B3-U0-G2	16175	146	B3-U0-G2									
IV-FT	13034	118				B2-U0-G3	13601	123	B2-U0-G3	14167	128	B2-U0-G3	14734	133	B2-U0-G3									
VSQ-N	14954	135				B3-U0-G1	15605	141	B3-U0-G1	16255	147	B4-U0-G1	16905	153	B4-U0-G2									
VSQ-M	14665	132				B4-U0-G2	15302	138	B4-U0-G2	15940	144	B4-U0-G2	16578	150	B4-U0-G2									
VSQ-W	14314	129				B4-U0-G3	14937	135	B4-U0-G3	15559	140	B4-U0-G3	16182	146	B4-U0-G3									
II-HS	10363	94				B1-U0-G2	10813	98	B1-U0-G2	11264	102	B1-U0-G2	11714	106	B1-U0-G2									
II-FR-HS	10541	95				B1-U0-G1	10999	99	B1-U0-G1	11458	103	B1-U0-G2	11916	108	B1-U0-G2									
III-M-HS	10484	95				B1-U0-G2	10940	99	B1-U0-G2	11396	103	B1-U0-G2	11852	107	B1-U0-G3									
III-W-HS	10262	93				B1-U0-G3	10708	97	B1-U0-G3	11154	101	B1-U0-G3	11600	105	B1-U0-G3									
IV-HS	10828	98				B1-U0-G2	11299	102	B1-U0-G2	11770	106	B1-U0-G2	12241	110	B1-U0-G2									
IV-FT-HS	10234	92				B1-U0-G3	10678	96	B1-U0-G3	11123	100	B1-U0-G3	11568	104	B1-U0-G3									
40	1050	135				II	16120	120	B3-U0-G3	16820	125	B3-U0-G3	17521	130	B3-U0-G3	18222	135	B3-U0-G3	N/A		N/A			
						II-FR	16228	120	B3-U0-G2	16934	126	B3-U0-G2	17639	131	B3-U0-G2	18345	136	B3-U0-G2						
						II-ML	16120	120	B4-U0-G4	16821	125	B4-U0-G4	17522	130	B4-U0-G4	18223	135	B4-U0-G4						
						III-M	16402	122	B3-U0-G3	17115	127	B3-U0-G3	17828	132	B3-U0-G3	18541	138	B3-U0-G3						
			III-W	15229	113	B2-U0-G3	15891	118	B3-U0-G3	16554	123	B3-U0-G3	17216	128	B3-U0-G3									
			IV	16279	121	B3-U0-G3	16987	126	B3-U0-G3	17694	131	B3-U0-G3	18402	137	B3-U0-G3									
			IV-FT	14829	110	B2-U0-G3	15474	115	B3-U0-G3	16118	120	B3-U0-G4	16763	124	B3-U0-G4									
			VSQ-N	17014	126	B4-U0-G2	17754	132	B4-U0-G2	18494	137	B4-U0-G2	19233	143	B4-U0-G2									
			VSQ-M	16684	124	B4-U0-G2	17410	129	B4-U0-G2	18135	135	B4-U0-G2	18861	140	B4-U0-G2									
			VSQ-W	16285	121	B4-U0-G3	16993	126	B5-U0-G3	17701	131	B5-U0-G3	18409	137	B5-U0-G3									
			II-HS	11789	87	B1-U0-G2	12302	91	B1-U0-G2	12814	95	B1-U0-G2	13327	99	B1-U0-G3									
			II-FR-HS	11993	89	B1-U0-G2	12514	93	B1-U0-G2	13035	97	B1-U0-G2	13557	101	B1-U0-G2									
			III-M-HS	11928	88	B1-U0-G3	12447	92	B1-U0-G3	12965	96	B1-U0-G3	13484	100	B1-U0-G3									
			III-W-HS	11674	87	B1-U0-G3</																		

PHOTOMETRIC DATA GUIDE - LUMEN TABLES (VLL-PLLED)

LED Count	Drive Current (mA)	System Watts	Dist'n Type	27K (2700K - 70CRI)			30K (3000K - 70CRI)			40K (4000K - 70CRI)			50K (5000K - 70CRI)			System Watts	TRA (590nm)		
				LUMENS	LPW	BUG RATING	LUMENS	LPW	BUG RATING	LUMENS	LPW	BUG RATING	LUMENS	LPW	BUG RATING		LUMENS	LPW	BUG RATING
40	1225	159	II	17939	113	B3-U0-G3	18720	118	B3-U0-G3	19499	123	B3-U0-G3	20279	128	B3-U0-G3	N/A	N/A		
			II-FR	18060	114	B3-U0-G2	18845	119	B3-U0-G2	19631	124	B3-U0-G2	20416	128	B3-U0-G2				
			II-ML	17940	113	B4-U0-G4	18720	118	B4-U0-G4	19501	123	B4-U0-G4	20281	128	B4-U0-G4				
			III-M	18254	115	B3-U0-G3	19047	120	B3-U0-G3	19841	125	B3-U0-G3	20635	130	B3-U0-G3				
			III-W	16949	107	B3-U0-G3	17686	111	B3-U0-G3	18423	116	B3-U0-G3	19160	121	B3-U0-G4				
			IV	18117	114	B3-U0-G3	18904	119	B3-U0-G3	19692	124	B3-U0-G3	20480	129	B3-U0-G3				
			IV-FT	16503	104	B3-U0-G4	17221	108	B3-U0-G4	17938	113	B3-U0-G4	18656	117	B3-U0-G4				
			VSQ-N	18935	119	B4-U0-G2	19758	124	B4-U0-G2	20582	130	B4-U0-G2	21405	135	B4-U0-G2				
			VSQ-M	18568	117	B4-U0-G2	19375	122	B4-U0-G2	20183	127	B4-U0-G2	20990	132	B4-U0-G2				
			VSQ-W	18124	114	B5-U0-G3	18912	119	B5-U0-G3	19700	124	B5-U0-G3	20488	129	B5-U0-G3				
			II-HS	13121	83	B1-U0-G3	13691	86	B1-U0-G3	14262	90	B1-U0-G3	14832	93	B1-U0-G3				
			II-FR-HS	13347	84	B1-U0-G2	13927	88	B1-U0-G2	14508	91	B1-U0-G2	15088	95	B1-U0-G2				
			III-M-HS	13275	84	B1-U0-G3	13852	87	B1-U0-G3	14429	91	B1-U0-G3	15006	94	B1-U0-G3				
			III-W-HS	12993	82	B1-U0-G3	13558	85	B1-U0-G3	14123	89	B1-U0-G3	14688	92	B1-U0-G3				
			IV-HS	13711	86	B1-U0-G3	14307	90	B1-U0-G3	14903	94	B1-U0-G3	15499	98	B1-U0-G3				
			IV-FT-HS	12957	82	B1-U0-G3	13521	85	B1-U0-G3	14084	89	B1-U0-G4	14647	92	B1-U0-G4				

IES File downloads for this product can be found at www.usaltg.com/downloads/asr.html

PHOTOMETRIC DATA GUIDE - LUMEN TABLES (VLL-PLD)

LED Count	Drive Current (mA)	System Watts	Dist'n Type	27K (2700K - 70CRI)			30K (3000K - 70CRI)			40K (4000K - 70CRI)			50K (5000K - 70CRI)			System Watts	TRA (590nm)		
				LUMENS	LPW	BUG RATING	LUMENS	LPW	BUG RATING	LUMENS	LPW	BUG RATING	LUMENS	LPW	BUG RATING		LUMENS	LPW	BUG RATING
80	350	N/A	II	N/A	N/A	N/A	N/A	N/A	N/A	N/A	N/A	N/A	N/A	67	4475	67	B1-U0-G1		
			II-FR												4504	67	B1-U0-G1		
			II-ML												4475	67	B2-U0-G2		
			III-M												4553	68	B1-U0-G1		
			III-W												4228	63	B1-U0-G2		
			IV												4518	67	B1-U0-G1		
			IV-FT												4117	61	B1-U0-G1		
			VSQ-N												4723	70	B2-U0-G1		
			VSQ-M												4631	69	B3-U0-G1		
			VSQ-W												4520	67	B3-U0-G2		
			II-HS												3273	49	B0-U0-G1		
			II-FR-HS												3329	50	B0-U0-G1		
			III-M-HS												3311	49	B0-U0-G1		
			III-W-HS												3240	48	B0-U0-G1		
			IV-HS												3420	51	B0-U0-G1		
			IV-FT-HS												3232	48	B0-U0-G2		
80	525	N/A	II	N/A	N/A	N/A	N/A	N/A	N/A	N/A	N/A	N/A	101	5251	52	B1-U0-G1			
			II-FR											5286	52	B1-U0-G1			
			II-ML											5251	52	B2-U0-G2			
			III-M											5343	53	B1-U0-G2			
			III-W											4961	49	B1-U0-G2			
			IV											5302	52	B1-U0-G1			
			IV-FT											4830	48	B1-U0-G2			
			VSQ-N											5542	55	B2-U0-G1			
			VSQ-M											5434	54	B3-U0-G1			
			VSQ-W											5304	53	B3-U0-G2			
			II-HS											3841	38	B0-U0-G1			
			II-FR-HS											3906	39	B0-U0-G1			
			III-M-HS											3885	38	B0-U0-G1			
			III-W-HS											3803	38	B0-U0-G2			
			IV-HS											4013	40	B0-U0-G1			
			IV-FT-HS											3792	38	B0-U0-G2			
80	700	174	II	22914	132	B3-U0-G3	23910	138	B3-U0-G3	24906	144	B3-U0-G3	25902	149	B3-U0-G3	N/A	N/A		
			II-FR	23068	133	B3-U0-G2	24070	139	B3-U0-G2	25073	145	B3-U0-G2	26076	150	B3-U0-G2				
			II-ML	22914	132	B4-U0-G4	23910	138	B4-U0-G4	24907	144	B4-U0-G4	25903	149	B4-U0-G4				
			III-M	23314	134	B3-U0-G3	24328	140	B3-U0-G3	25342	146	B3-U0-G3	26355	152	B3-U0-G4				
			III-W	21647	125	B3-U0-G4	22589	130	B3-U0-G4	23530	136	B3-U0-G4	24471	141	B3-U0-G4				
			IV	23139	133	B3-U0-G3	24145	139	B3-U0-G3	25152	145	B3-U0-G4	26158	151	B3-U0-G4				
			IV-FT	21079	121	B3-U0-G4	21995	127	B3-U0-G4	22911	132	B3-U0-G4	23828	137	B3-U0-G4				
			VSQ-N	24184	139	B4-U0-G2	25236	145	B4-U0-G2	26287	152	B4-U0-G2	27339	158	B5-U0-G2				
			VSQ-M	23716	137	B5-U0-G3	24747	143	B5-U0-G3	25778	149	B5-U0-G3	26809	155	B5-U0-G3				
			VSQ-W	23149	133	B5-U0-G4	24156	139	B5-U0-G4	25162	145	B5-U0-G4	26169	151	B5-U0-G4				
			II-HS	16758	97	B1-U0-G3	17486	101	B1-U0-G3	18215	105	B1-U0-G3	18944	109	B1-U0-G3				
			II-FR-HS	17046	98	B1-U0-G2	17788	103	B1-U0-G2	18529	107	B1-U0-G2	19270	111	B1-U0-G2				
			III-M-HS	16954	98	B1-U0-G3	17691	102	B1-U0-G4	18428	106	B1-U0-G4	19165	110	B1-U0-G4				
			III-W-HS	16595	96	B1-U0-G4	17316	100	B1-U0-G4	18038	104	B1-U0-G4	18759	108	B1-U0-G4				
			IV-HS	17511	101	B1-U0-G3	18272	105	B1-U0-G3	19034	110	B1-U0-G3	19795	114	B1-U0-G4				
			IV-FT-HS	16549	95	B1-U0-G4	17269	100	B1-U0-G4	17988	104	B1-U0-G4	18708	108	B1-U0-G4				
80	875	222	II	27459	124	B3-U0-G4	28653	129	B3-U0-G4	29847	135	B4-U0-G4	31040	140	B4-U0-G4	N/A	N/A		
			II-FR	27643	125	B3-U0-G2	28845	130	B4-U0-G2	30047	136	B4-U0-G2	31249	141	B4-U0-G2				
			II-ML	27460	124	B4-U0-G4	28654	129	B4-U0-G4	29848	135	B5-U0-G5	31042	140	B5-U0-G5				
			III-M	27939	126	B3-U0-G4	29154	132	B3-U0-G4	30369	137	B3-U0-G4	31583	143	B4-U0-G4				
			III-W	25942	117	B3-U0-G4	27070	122	B3-U0-G4	28198	127	B3-U0-G4	29326	132	B3-U0-G5				
			IV	27730	125	B3-U0-G4	28935	131	B3-U0-G4	30141	136	B3-U0-G4	31346	142	B4-U0-G4				
			IV-FT	25260	114	B3-U0-G5	26358	119	B3-U0-G5	27456	124	B3-U0-G5	28555	129	B3-U0-G5				
			VSQ-N	28982	131	B5-U0-G2	30242	137	B5-U0-G2	31502	142	B5-U0-G2	32762	148	B5-U0-G2				
			VSQ-M	28420	128	B5-U0-G3	29656	134	B5-U0-G3	30892	139	B5-U0-G3	32127	145	B5-U0-G4				
			VSQ-W	27742	125	B5-U0-G4	28948	131	B5-U0-G4	30154	136	B5-U0-G4	31360	142	B5-U0-G4				
			II-HS	20082	91	B1-U0-G4	20955	95	B2-U0-G4	21828	99	B2-U0-G4	22701	102	B2-U0-G4				
			II-FR-HS	20428	92	B1-U0-G2	21316	96	B1-U0-G2	22204	100	B1-U0-G2	23092	104	B1-U0-G2				
			III-M-HS	20317	92	B1-U0-G4	21201	96	B1-U0-G4	22084	100	B1-U0-G4	22967	104	B1-U0-G4				
			III-W-HS	19887	90	B1-U0-G4	20752	94	B1-U0-G4	21616	98	B1-U0-G4	22480	101	B1-U0-G4				
			IV-HS	20985	95	B1-U0-G4	21897	99	B1-U0-G4	22810	103	B1-U0-G4	23722	107	B1-U0-G4				
			IV-FT-HS	19832	90	B1-U0-G4	20694	93	B1-U0-G4	21557	97	B1-U0-G4	22419	101	B1-U0-G5				
80	1050	270	II	31240	116	B4-U0-G4	32598	121	B4-U0-G4	33957	126	B4-U0-G4	35315	131	B4-U0-G4	N/A	N/A		
			II-FR	31450	117	B4-U0-G2	32817	122	B4-U0-G2	34185	127	B4-U0-G2	35552	132	B4-U0-G2				
			II-ML	31241	116	B5-U0-G5	32600	121	B5-U0-G5	33958	126	B5-U0-G5	35317	131	B5-U0-G5				
			III-M	31787	118	B4-U0-G4	33169	123	B4-U0-G4	34551	128	B4-U0-G4	35933	133	B4-U0-G4				
			III-W	29514	110	B3-U0-G5	30797	114	B3-U0-G5	32080	119	B3-U0-G5	33364	124	B3-U0-G5				
			IV	31548	117	B4-U0-G4	32920	122	B4-U0-G4	34291	127	B4-U0-G4	35663	132	B4-U0-G4				
			IV-FT	28738	107	B3-U0-G5	29987	111	B3-U0-G5	31237	116	B3-U0-G5	32487	121	B3-U0-G5				
			VSQ-N	32973	122	B5-U0-G2	34406	128	B5-U0-G2	35840	133	B5-U0-G2	37274	138	B5-U0-G2				
			VSQ-M	32334	120	B5-U0-G4	33740	125	B5-U0-G4	35145	130	B5-U0-G4	36551	136	B5-U0-G4				
			VSQ-W	31561	117	B5-U0-G5	32934	122	B5-U0-G5	34306	127	B5-U0-G5	35678	132	B5-U0-G5				
			II-HS	22847	85	B2-U0-G4	23841	88	B2-U0-G4	24834	92	B2-U0-G4	25827	96	B2-U0-G4				
			II-FR-HS	23241	86	B1-U0-G2	24251	90	B1-U0-G2	25262	94	B1-U0-G2	26272	97	B2-U0-G2				
			III-M-HS	23115	86	B1-U0-G4	24120	89	B1-U0-G4	25125	93	B1-U0-G4	26130	97	B1-U0-G4				
			III-W-HS	22625	84	B1-U0-G4	23609	88	B1-U0-G5	24592	91	B1-U0-G5	25576	95	B1-U0-G5				
			IV-HS	23874	89	B1-U0-G4	24913	92	B1-U0-G4	25950	96	B1-U0-G4	26988	100	B1-U0-G4				
			IV-FT-HS	22563	84	B1-U0-G5	23545	87	B1-U0-G5	24525	91	B1-U0-G5	25506	95	B1-U0-G5				

IES File downloads for this product can be found at www.usaltg.com/downloads/asr.html

PHOTOMETRIC DATA GUIDE - LUMEN TABLES (VLL-PLD)

LED Count	Drive Current (mA)	System Watts	Dist'n Type	27K (2700K - 70CRI)			30K (3000K - 70CRI)			40K (4000K - 70CRI)			50K (5000K - 70CRI)			System Watts	TRA (590nm)											
				LUMENS	LPW	BUG RATING	LUMENS	LPW	BUG RATING	LUMENS	LPW	BUG RATING	LUMENS	LPW	BUG RATING		LUMENS	LPW	BUG RATING									
80	1225	318	II	34767	109	B4-U0-G4	36279	114	B4-U0-G4	37790	119	B4-U0-G4	39302	124	B4-U0-G4	N/A	N/A											
			II-FR	35001	110	B4-U0-G2	36523	115	B4-U0-G2	38044	120	B4-U0-G2	39566	124	B4-U0-G2													
			II-ML	34769	109	B5-U0-G5	36280	114	B5-U0-G5	37792	119	B5-U0-G5	39304	124	B5-U0-G5													
			III-M	35375	111	B4-U0-G4	36913	116	B4-U0-G4	38451	121	B4-U0-G5	39989	126	B4-U0-G5													
			III-W	32846	103	B3-U0-G5	34274	108	B3-U0-G5	35702	112	B3-U0-G5	37131	117	B3-U0-G5													
			IV	35110	110	B4-U0-G4	36636	115	B4-U0-G4	38163	120	B4-U0-G4	39689	125	B4-U0-G5													
			IV-FT	31983	101	B3-U0-G5	33373	105	B3-U0-G5	34764	109	B3-U0-G5	36155	114	B3-U0-G5													
			VSQ-N	36696	115	B5-U0-G2	38291	120	B5-U0-G2	39887	125	B5-U0-G2	41482	130	B5-U0-G2													
			VSQ-M	35985	113	B5-U0-G4	37549	118	B5-U0-G4	39114	123	B5-U0-G4	40678	128	B5-U0-G4													
			VSQ-W	35125	110	B5-U0-G5	36652	115	B5-U0-G5	38179	120	B5-U0-G5	39706	125	B5-U0-G5													
			II-HS	25427	80	B2-U0-G4	26533	83	B2-U0-G4	27638	87	B2-U0-G4	28744	90	B2-U0-G4													
			II-FR-HS	25865	81	B2-U0-G2	26989	85	B2-U0-G2	28114	88	B2-U0-G2	29239	92	B2-U0-G2													
			III-M-HS	25725	81	B1-U0-G4	26843	84	B1-U0-G4	27962	88	B1-U0-G5	29080	91	B1-U0-G5													
			III-W-HS	25179	79	B1-U0-G5	26274	83	B1-U0-G5	27369	86	B1-U0-G5	28464	90	B1-U0-G5													
			IV-HS	26570	84	B1-U0-G4	27725	87	B1-U0-G4	28881	91	B1-U0-G4	30036	94	B1-U0-G4													
			IV-FT-HS	25111	79	B1-U0-G5	26202	82	B1-U0-G5	27294	86	B1-U0-G5	28386	89	B1-U0-G5													
			80	1400	366	II	37677	103	B4-U0-G4	39315	107	B4-U0-G4	40953	112	B4-U0-G4						42591	116	B4-U0-G5	N/A	N/A			
						II-FR	37930	104	B4-U0-G2	39579	108	B4-U0-G2	41228	113	B4-U0-G3						42877	117	B4-U0-G3					
II-ML	37678	103				B5-U0-G5	39317	107	B5-U0-G5	40955	112	B5-U0-G5	42593	116	B5-U0-G5													
III-M	38336	105				B4-U0-G5	40003	109	B4-U0-G5	41670	114	B4-U0-G5	43337	118	B4-U0-G5													
III-W	35595	97				B3-U0-G5	37143	101	B3-U0-G5	38690	106	B3-U0-G5	40238	110	B4-U0-G5													
IV	38048	104				B4-U0-G4	39703	108	B4-U0-G5	41357	113	B4-U0-G5	43011	117	B4-U0-G5													
IV-FT	34659	95				B3-U0-G5	36166	99	B3-U0-G5	37673	103	B4-U0-G5	39180	107	B4-U0-G5													
VSQ-N	39767	109				B5-U0-G2	41496	113	B5-U0-G2	43225	118	B5-U0-G2	44954	123	B5-U0-G2													
VSQ-M	38996	106				B5-U0-G4	40692	111	B5-U0-G4	42387	116	B5-U0-G4	44082	120	B5-U0-G4													
VSQ-W	38065	104				B5-U0-G5	39720	108	B5-U0-G5	41374	113	B5-U0-G5	43029	118	B5-U0-G5													
II-HS	27555	75				B2-U0-G4	28753	79	B2-U0-G4	29951	82	B2-U0-G4	31149	85	B2-U0-G4													
II-FR-HS	28030	77				B2-U0-G2	29248	80	B2-U0-G2	30467	83	B2-U0-G2	31686	87	B2-U0-G3													
III-M-HS	27878	76				B1-U0-G5	29090	79	B1-U0-G5	30302	83	B1-U0-G5	31514	86	B1-U0-G5													
III-W-HS	27287	75				B1-U0-G5	28474	78	B1-U0-G5	29660	81	B1-U0-G5	30846	84	B1-U0-G5													
IV-HS	28794	79				B1-U0-G4	30046	82	B1-U0-G4	31298	85	B1-U0-G5	32550	89	B1-U0-G5													
IV-FT-HS	27213	74				B1-U0-G5	28396	78	B1-U0-G5	29579	81	B1-U0-G5	30762	84	B1-U0-G5													

IES File downloads for this product can be found at www.usalgt.com/downloads/asr.html